

ESCALATOR GEAR UNITS

All product types and dimensions

Table of content

Precision in motion – this is what AUMA Drives stands for. As a specialist in high-performance drive technology, we deliver customized gear solutions for demanding industrial applications. Our portfolio ranges from standard gearboxes to highly engineered drive systems tailored to exacting customer specifications. With decades of expertise, advanced in-house manufacturing, and a strong commitment to quality, AUMA

Drives is your partner for reliable, efficient, and future-ready power transmission solutions.

This catalogue presents our comprehensive range of drive technologies – developed to move what matters, with precision you can trust.

- Introduction** **04**

- Overview: Product Lines** **08**

- FTS.1 Series** **13**
 - FTS 125.1 17
 - FTS 160.1 21
 - FTS 180.1 25

- FTSST.1 Series** **29**
 - FTSST 158.1 33
 - FTSST 180.1 38
 - FTSST 212.1 44
 - FTSST 260.1 49

- HYMAX FTHST.1 Series** **53**
 - FTHST 156.1 57
 - FTHST 168.1 61
 - FTHST 182.1 65

AUMA Drives

Our name means highest precision, engineering art and customised solutions in manufacturing gear units and drive systems. Safety-relevant applications such as the transport of people have always been a core automation competence for our gear units. We have complemented the elevator drive range by AUMA Drives escalator gear units for more than a decade.

More than 60,000 AUMA Drives escalator gear units are reliably automating escalators in airports, underground stations and

department stores worldwide. With our single-stage and multi-stage gearbox series – and going beyond with the so-called twin drives – we cover motor power between 5 kW and 90 kW. The major assets of escalator gear units are their capability to withstand high loads and their functional safety, long running times, reliability and efficiency. We offer 100 % traceability for all components within the power drive.





Escalator gear units without compromise

No matter whether you go to airports, underground stations or department stores – It is impossible to imagine everyday life without escalators. The core of all systems is the drive technology, imperatively meeting highest demands: a matter of course for AUMA Drives. We guarantee high resilience and functional safety, long service performance, reliability and economic viability.

From the single part to the complete gearbox, all production steps are subject to continuous quality control – from incoming goods to final inspection at the acoustic measurement room. Our products fulfil all requirements of relevant standards according to the customer's product specifications.

Our development process

"Customized Solutions" at AUMA Drives is more than just a buzzword. It represents a commitment that guides every step of the development process. This is because "customer-specific solutions" require clearly structured processes in the design and development of gear units and drive systems – from the initial project sketch to the finished product. The goal is to create a product whose performance and efficiency become a competitive advantage for the customer.

With this ambition, every customer project at AUMA Drives goes through several stages, all of which are carried out entirely in-house.

Production

At the core of our reputation lies a meticulously structured and technologically advanced production process. This vertically integrated manufacturing approach ensures tight quality control, flexible customization, and efficient lead times for a global clientele. This process is a model of precision, efficiency, and adaptability. By combining tradition with innovation and automation, we ensure that our products are not only technically superior but also reliable and future-ready.

1. In-House Manufacturing and Vertical Integration

We maintain a remarkably high level of vertical integration, manufacturing virtually all key components in-house. This includes gear parts, housing elements, shafts. This is where worm shafts are precision-ground using high-accuracy grinding machines to meet stringent performance and noise-level requirements. Simultaneously, worm wheels are cut using eight CNC-controlled gear hobbing machines.

2. Housing and Component Machining

All housing parts, are milled and drilled in-house using CNC machining centres. These machines handle castings of up to 2,000 kg, allowing for robust and stable housing components critical to mechanical longevity. The use of 3D CAD and CAM programming ensures high dimensional accuracy and efficient tool paths, minimizing rework and waste.

3. Surface Treatment and Coating

AUMA Drives operates two powder coating lines and two wet painting booths. The powder coating process includes a fully automated 8-zone pretreatment system that thoroughly cleans and preps components, ensuring excellent adhesion. Workpieces up to 300 kg can be uniformly coated, protecting them against harsh environmental conditions.





Do you want to learn more?

Visit our website and explore our production process digitally.



www.auma-drives.com

4. Assembly and Modular Testing

Pre-assembled modules are combined into complete drive systems in a dedicated assembly area. Modular construction principles allow for scalable configurations and simplified maintenance. During assembly, each component is matched according to its serial number, ensuring traceability and documentation throughout the system's lifecycle. Every finished drive undergoes functional testing.

5. Clean Energy and Smart Manufacturing

Sustainability is integrated into AUMA's production strategy. The facilities are equipped with energy-efficient machines, and process heat from production is reused to heat buildings. Lean production methods and continuous improvement principles are actively pursued to reduce waste and increase throughput. Digital process monitoring is used throughout the production chain.

Product Lines

HYMAX FTHST.1 Series

Hypoid-Helical-Gearbox Page 53

 PREMIUM-EFFICIENCY

FTSST.1 Series

Worm-Helical-Gearbox Page 29

 HIGH-EFFICIENCY

FTS.1 Series

Worm-Gearbox Page 13

 ECONOMICAL



An overview

Our comprehensive product portfolio and the large number of possible transmission ratios offer many selection criteria for finding the optimum gear unit for your application and hence a cost-efficient drive solution. Rated motor power and speed and the desired speed at the pinion are decisive for the gear unit type, size and transmission ratio.

Escalator gearboxes from the **FTS.1 series** are singlestage worm gearboxes that are mostly used in malls, department stores, residential and administrative buildings. Worm gears are characterized by a high overload capacity, are particularly low-noise, transmit the torque very evenly and thus ensure a high level of ride comfort. Three sizes, each with two gear ratios, cover the power range from 5 to 25kW.

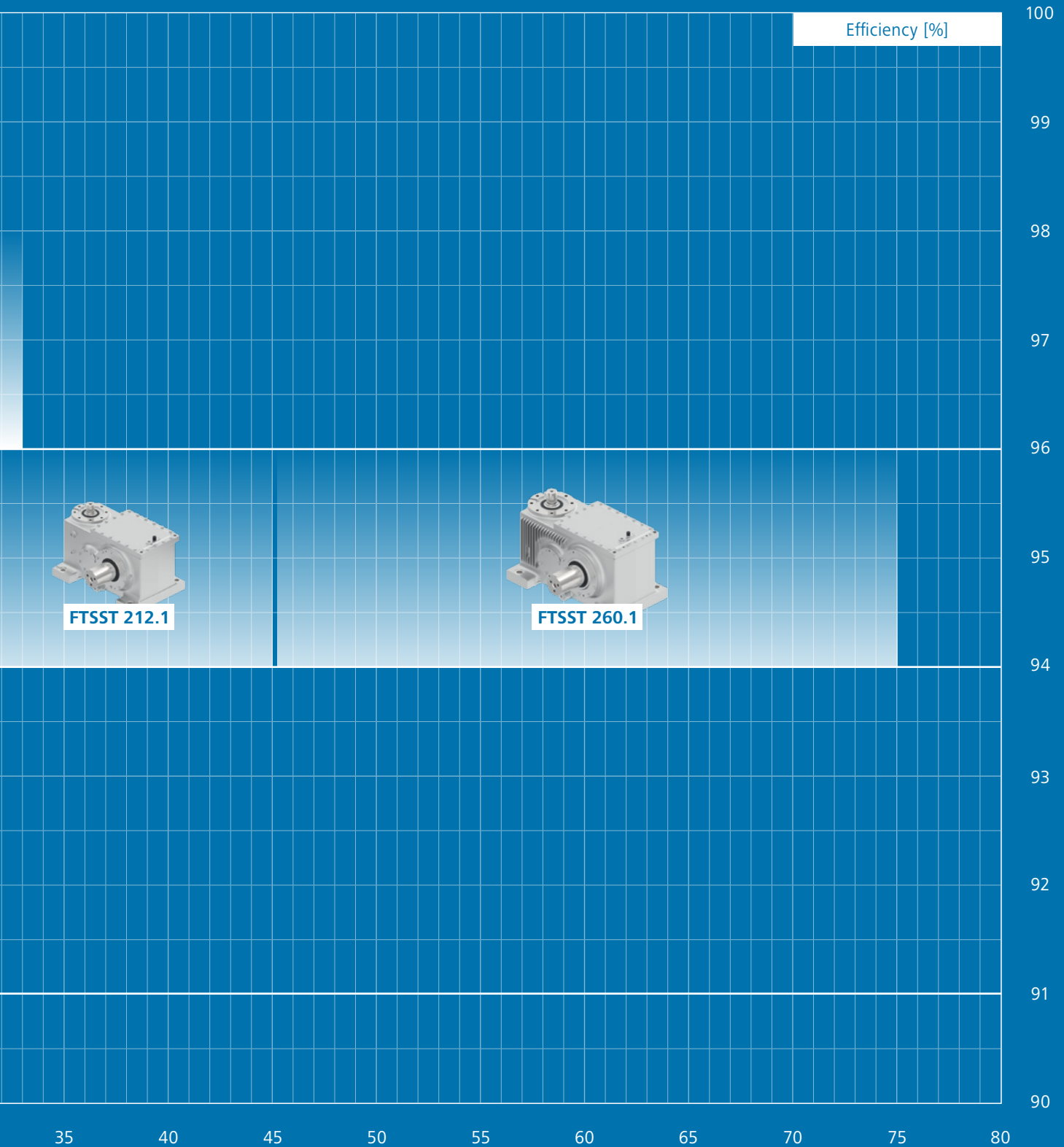

Escalator gearboxes from the **FTSST.1 series** are helical-worm gearboxes that are used in applications with 24/7 operation, for example at airports, railroad stations and metro stations. They combine the advantages of worm gearboxes, such as the very low noise level and even power transmission, with the higher efficiency of helical gears. Four sizes, each with three gear ratios, cover the power range from 10 to 75 kW.

HYMAX escalator gearboxes from the **FTHST.1 series** are two-stage gearboxes, a combination of a hypoid stage followed by a spur gear stage. Developed according to the latest technology and designed for maximum efficiency, the gearboxes are extremely compact and predestined for continuous operation applications, such as at airports, railroad stations and metro stations. Three sizes, each with two ratios, cover the power range from 10 to 33 kW.

Gear Unit Selection

After selecting the type series and size, as well as the transmission ratio, the resulting service life and the permissible radial force on the output shaft can be determined for the desired type. Determination of computed lifetime is based on the load spectrum of the escalator application. The load

spectrum represents the varying loads due to fluctuating number of people to be transported during the day. By means of the computed equivalent power P_{eq} lifetime and permissible radial force are determined on the basis of graphs. The course of action is demonstrated by means of the following example:

1. Load spectrum (example)

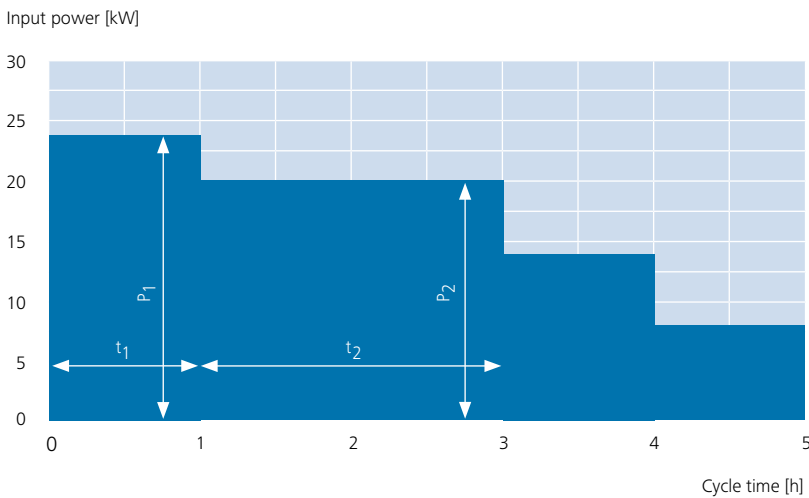

Example

- Load event 1 = 24 kW across 1/5 of time
- Load event 2 = 20 kW across 2/5 of time
- Load event 3 = 14 kW across 1/5 of time
- Load event 4 = 8 kW across 1/5 of time

2. Cycle time

$$t_{tot} = t_1 + t_2 + t_3 + \dots + t_i$$

3. Equivalent power P_{eq}

$$P_{eq} = \sqrt[3]{P_1^3 \times \frac{t_1}{t_{tot}} + P_2^3 \times \frac{t_2}{t_{tot}} + P_3^3 \times \frac{t_3}{t_{tot}} + \dots + P_i^3 \times \frac{t_i}{t_{tot}}}$$

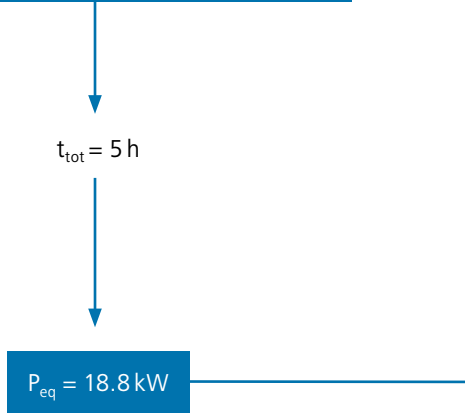

4. Graphic determination of resulting lifetime and permissible radial force at output shaft

Transmission ratio 20.4

Gear unit selected as example: FTSST 180.1 with transmission ratio $i=20.4$ and motor speed of 1,480 rpm.

Lubrication	Polyglycol	
Ambient temperature	40 °C	
Efficiency	$\geq 94\%$	
Max. output torque	6.5 kNm (according to EN 115 » safety factor ≥ 5)	$\alpha = 0 \dots 60^\circ$
Max. radial force	71 kN (according to EN 115 » safety factor ≥ 5)	$x = 300\text{ mm}$

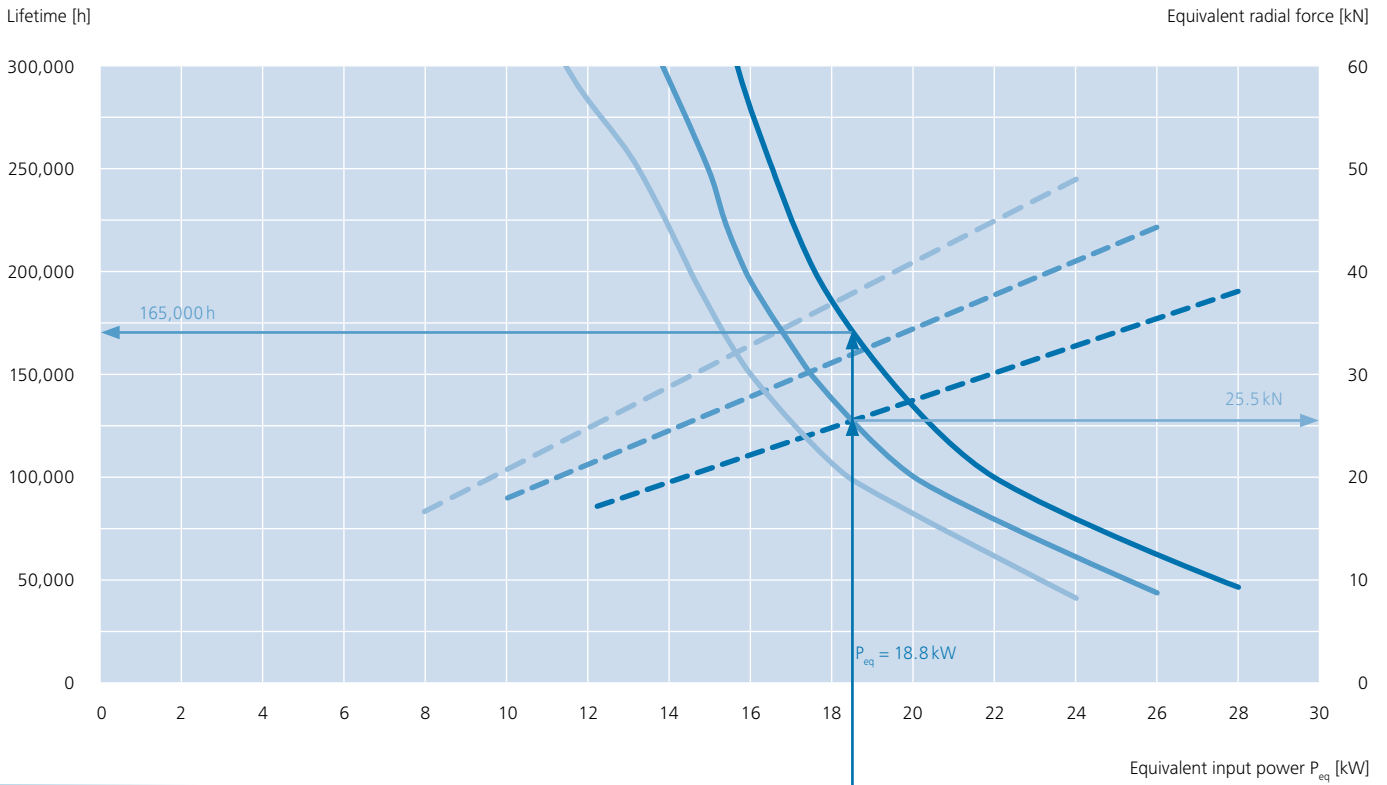
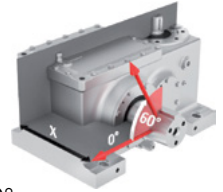

Lifetime	Radial force	Input speed [rpm]	Max. rated motor power [kW]	Max. rated radial force [kN]
—————	-----	980	30.0	61
—————	-----	1,180	30.0	51
—————	-----	1,480	30.0	41

5. Result

The selected gear unit FTSST 180.1 with reduction ratio $i = 20.4$ achieves a computed lifetime of 165,000 hours. The permissible radial load on the output shaft at $\alpha = 60^\circ$ is 25.5 kN.



FTS.1 Series

Worm-Gearbox

FTS 125.1

FTS 160.1

FTS 180.1

Design and Characteristics

Escalator gearboxes from the FTS.1 series are single-stage worm gearboxes that are mostly used in malls, department stores, residential and administrative buildings. Various outstanding features have established our gear units as first class escalator gear units. Vibration and shock-absorbing torque transmission, one of the main assets of worm gear units, means low-noise transport and therefore convenience for the passengers. Worm gearings with ZK type tooth profile optimized for this purpose, have high overload capabilities and are therefore ideally suited for frequent load changes in daily

operation. This is achieved by implementing grinded worm shafts made of case-hardened steel and worm wheels made of highly wear resistant special bronze. Worm gearings correspond to DIN 3996:2012, the latest method for calculation of load capacity. All machine elements within AUMA Drives escalator gear units meet the safety factor ≥ 5 according to EN 115:2010. FEM optimized housings warrant for maximum stiffness and consequently reduced vibration within the powertrain. Three sizes, each with two gear ratios, cover the power range from 5 to 25kW.

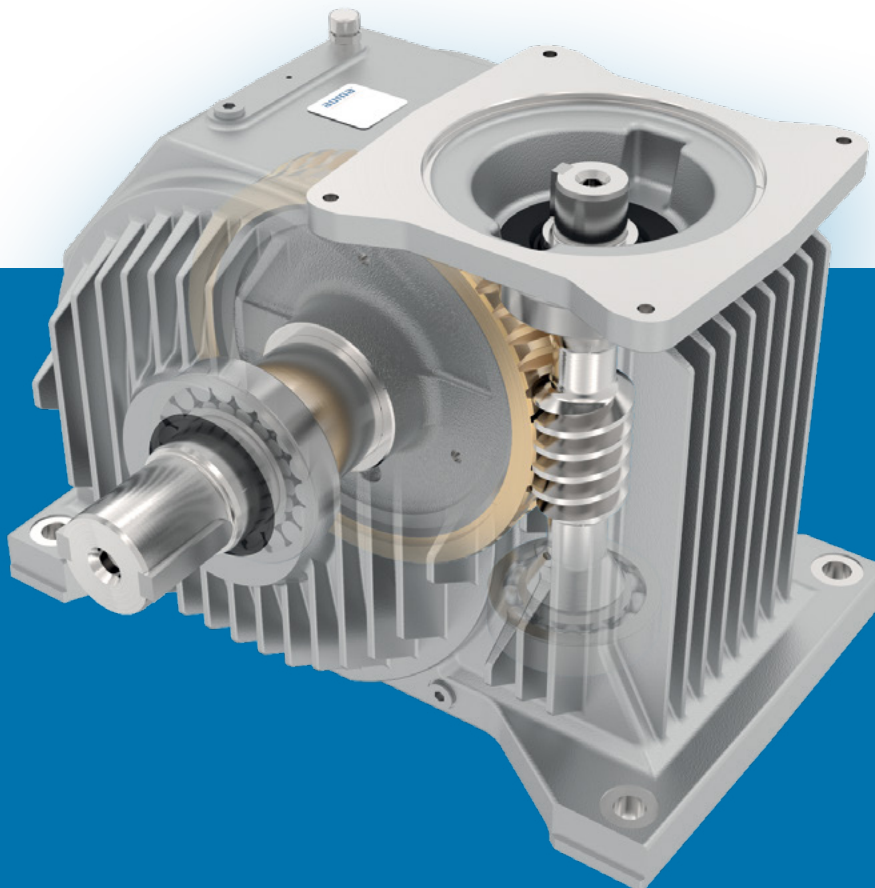

Noise emission, efficiency and lifetime

With regard to low-noise applications and noise emissions, worm gear units will always be the measure of all things. In our in-house acoustic measurement room complying with DIN standards, the acoustic pressure level of our escalator gear units is measured and recorded as part of final inspection.

Machining of worm wheel sets on state-of-the-art equipment as well as unique measuring technology, partially in special development projects in close cooperation with our partners, ensure optimum gear quality. When using synthetic polyglycol lubricants, typical heavy industry worm gearings achieve an efficiency rating of up to 97% thanks to our gearing optimisation technology. Paired with the implementation of top grade materials, selected standard

parts and high precision housing machining, maximum service life and highest reliability are achieved. The evidence of these results were confirmed by internal verifications and tests on customers' test benches.

Options and mounting parts

If specifically desired, AUMA Drives escalator gear units can be provided with integrated sensor technology for monitoring oil level, oil sump temperature and system vibration. When implemented in extremely low temperature environments, we offer an optional oil heater to ensure optimum lubrication as early as during the start-up phase.

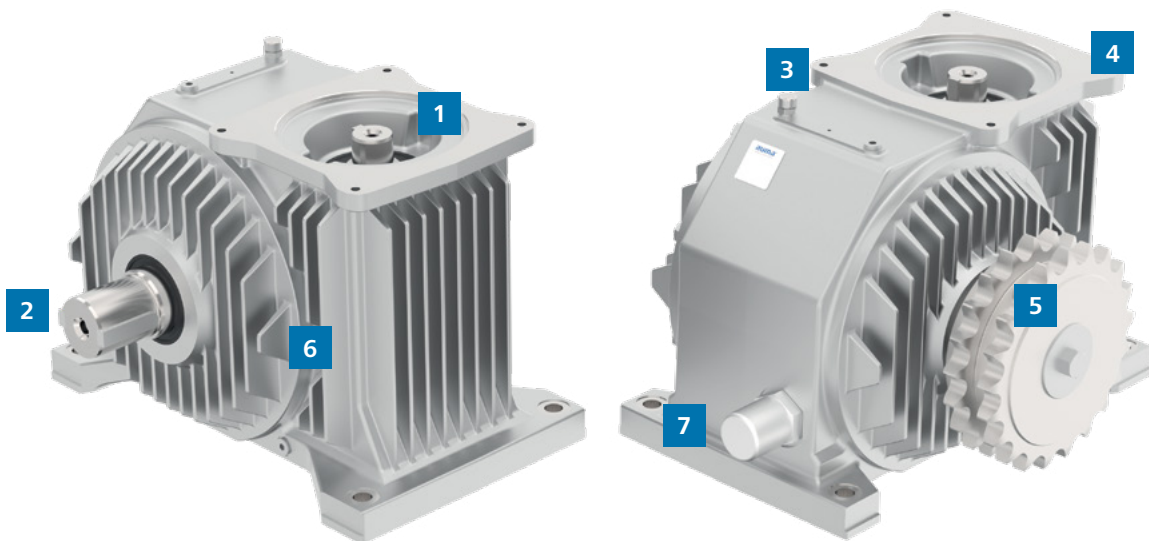

1 Input shaft

2 Output shaft

3 Air breather

4 Motor flange

5 Chain pinion / sprocket [option]

6 Oil sensor (temperature and level) [option]

7 Oil heater [option]

For a low-noise environment

AUMA Drives

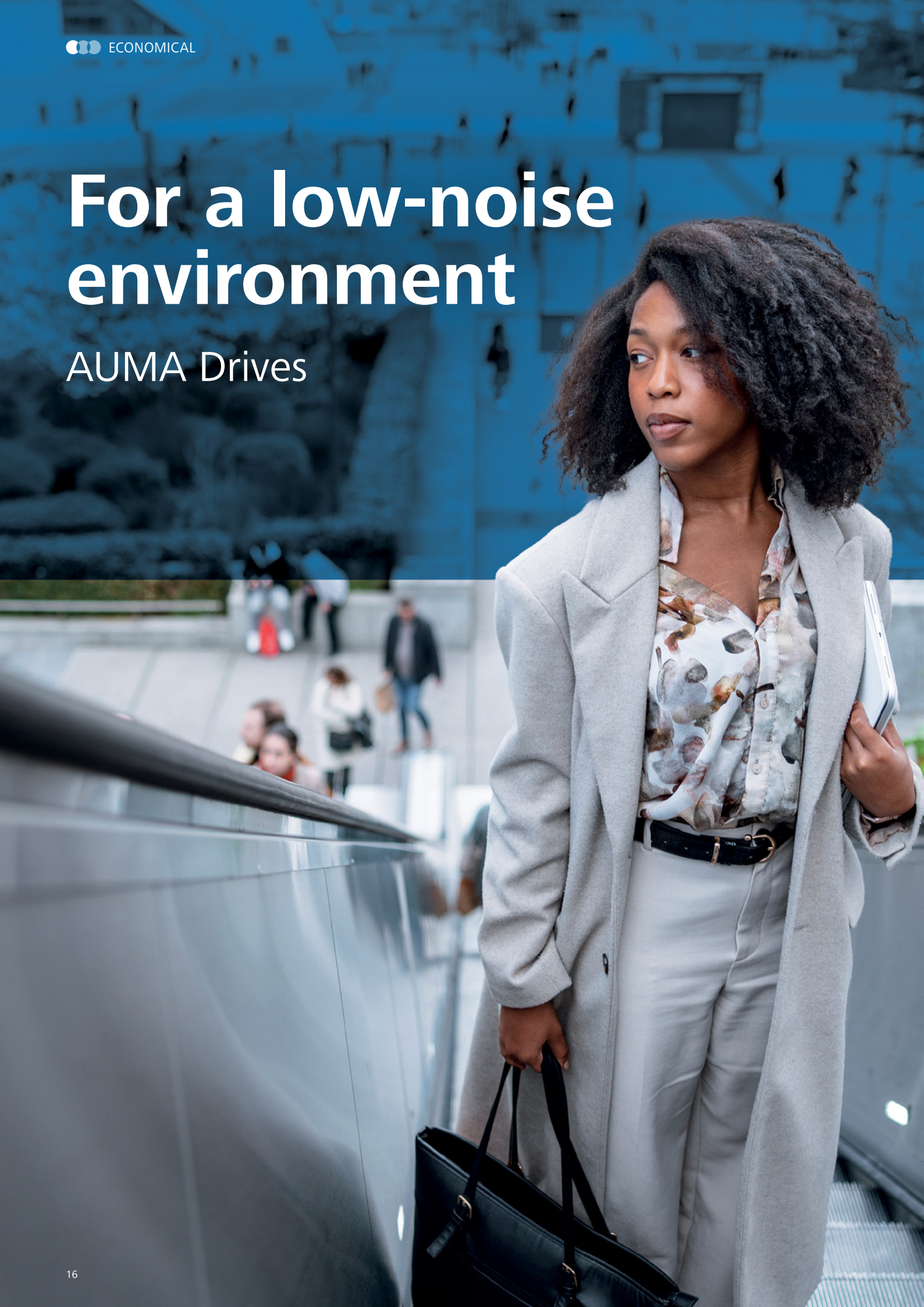

Dimension sheet

Type FTS 125.1

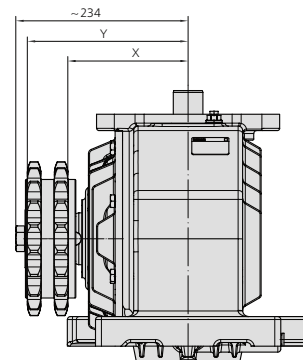
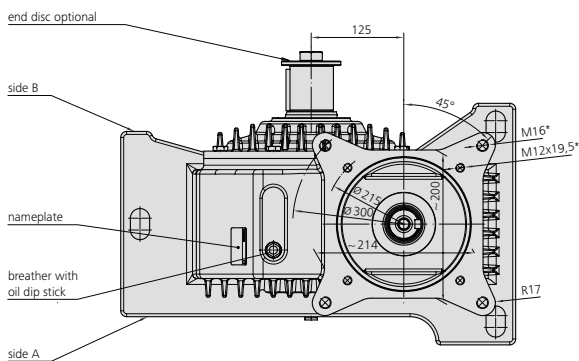
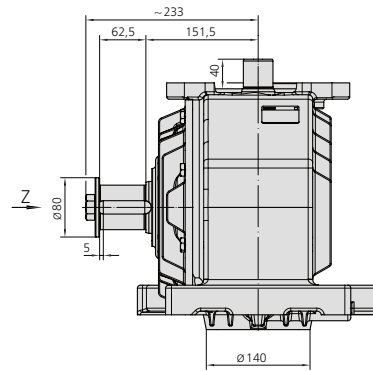
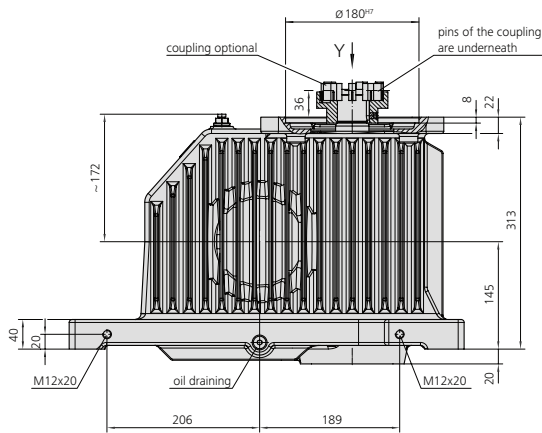
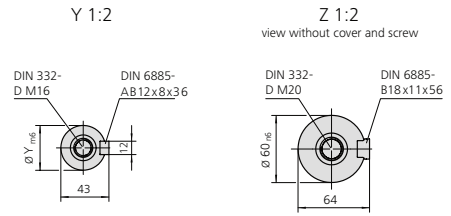
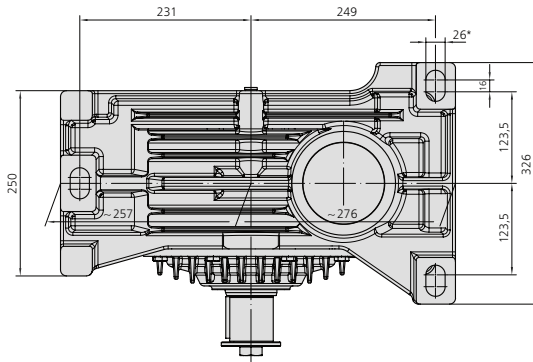

Pinion

Type of pinion	X [mm]	Y [mm]
Duplex-1 1/4" (double) for chains acc. to DIN 8187	162.3	216.9
Duplex-1 1/4" (double) for chains acc. to DIN 8188	163.9	216.9

* Strength class of screws 10.9

Type FTS 125.1

Performance

Transmission ratio 20.5

Lubrication	Polyglycol	
Ambient temperature	40 °C	
Efficiency	≥ 91 %	
Max. output torque	2.0 kNm (according to EN 115 » safety factor ≥ 5)	$\alpha = 60^\circ$
Max. radial force	17 kN (according to EN 115 » safety factor ≥ 5)	$x = 183 \text{ mm}$

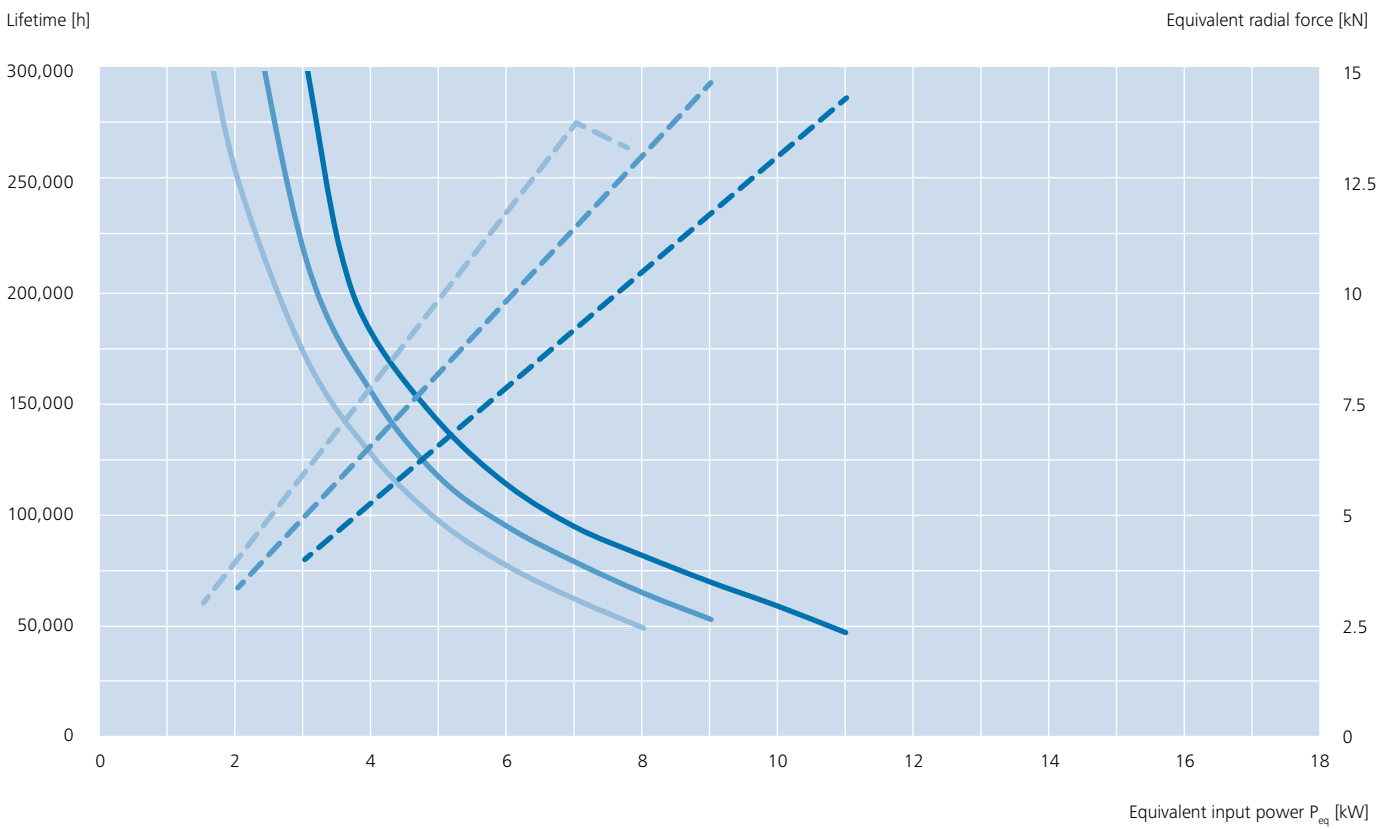

Lifetime	Radial force	Input speed [rpm]	Max. rated motor power [kW]	Max. rated radial force [kN]
—————	-----	980	9.0	17
—————	-----	1,180	9.5	15
—————	-----	1,480	10.5	14

The calculations of machine elements are based on the standards and guidelines reflecting the current state-of-the-art. Tooth profiles comply with the latest revision of DIN 3996:2012.

Performance

Type FTS 125.1

Transmission ratio 24.5

Lubrication Polyglycol
 Ambient temperature 40 °C
 Efficiency ≥ 91 %
 Max. output torque 2.0 kNm (according to EN 115 » safety factor ≥ 5)
 Max. radial force 17 kN (according to EN 115 » safety factor ≥ 5)

$\alpha = 60^\circ$
 $x = 183 \text{ mm}$

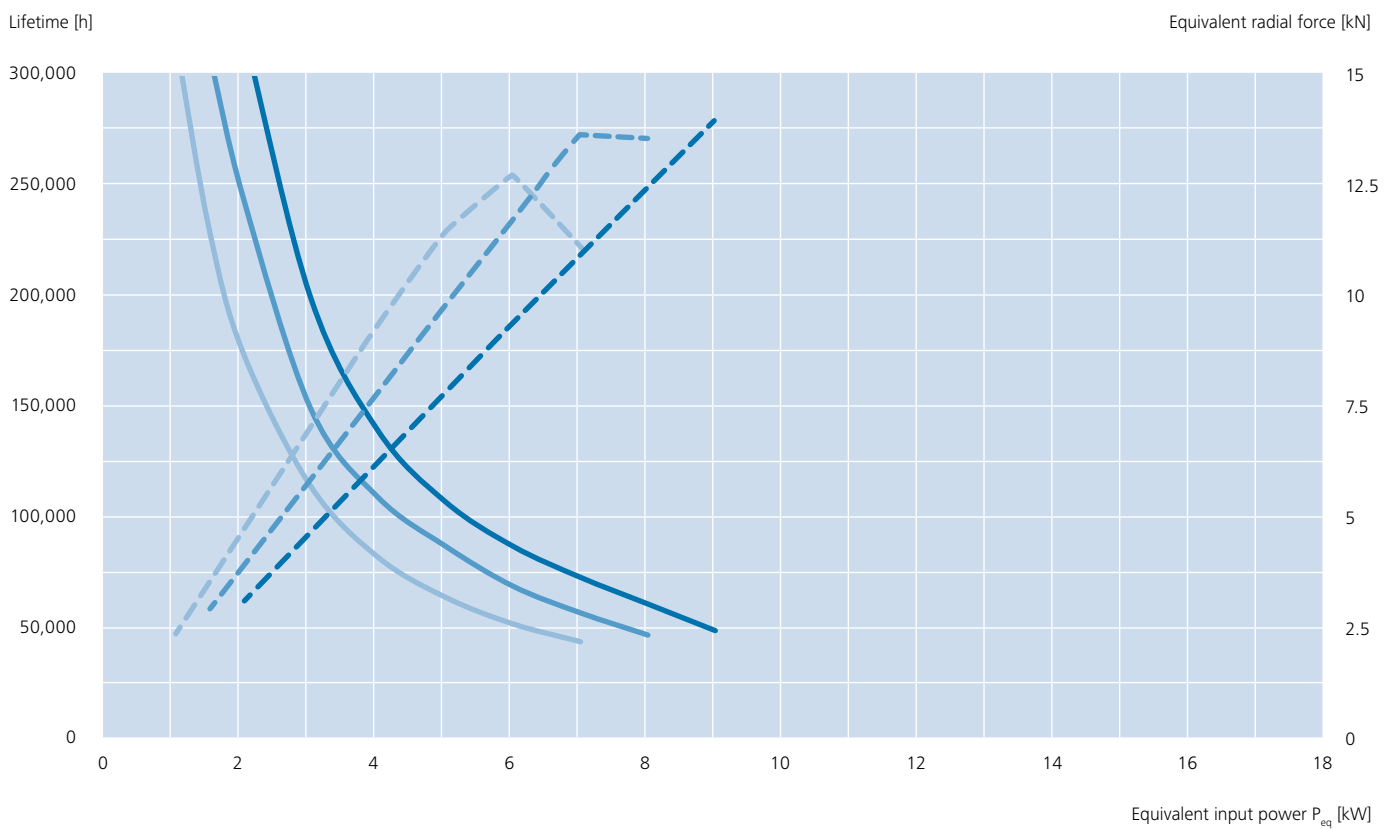

Lifetime	Radial force	Input speed [rpm]	Max. rated motor power [kW]	Max. rated radial force [kN]
—————	- - - - -	980	7.5	17
—————	- - - - -	1,180	8.0	15
—————	- - - - -	1,480	9.0	14

The calculations of machine elements are based on the standards and guidelines reflecting the current state-of-the-art. Tooth profiles comply with the latest revision of DIN 3996:2012.

When you value reliability

AUMA Drives

Dimension Sheet

Type FTS 160.1

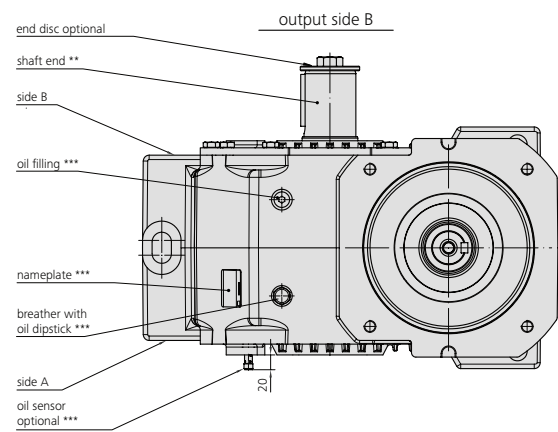
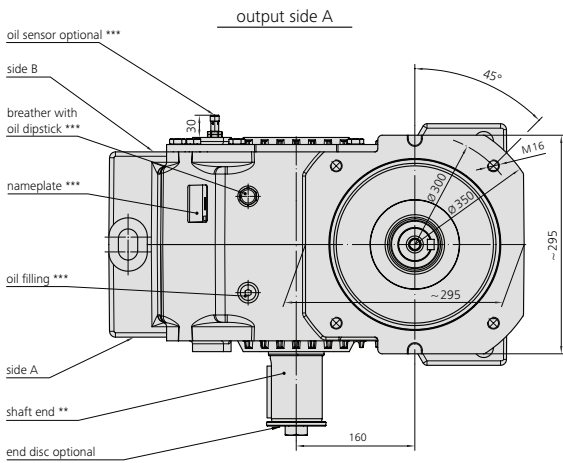
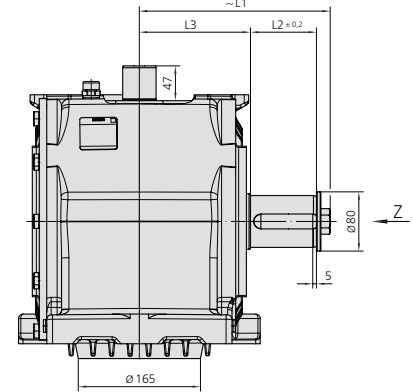
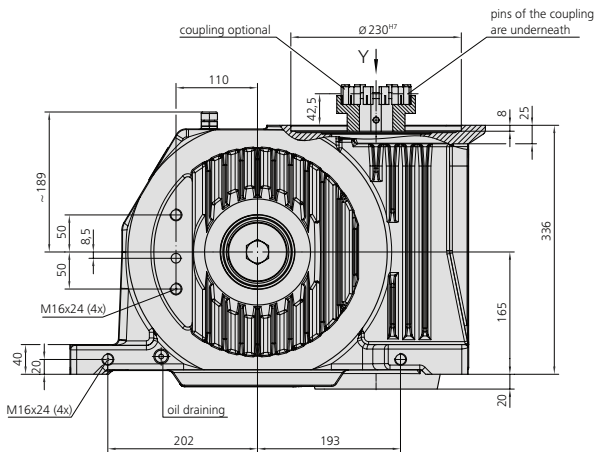
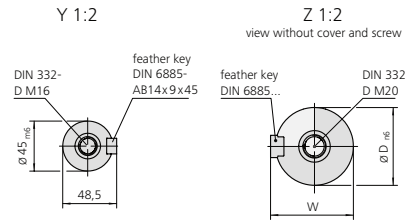
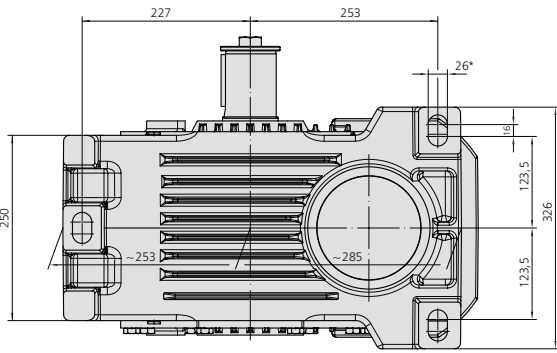

Pinion										
Type of pinion	ØD [mm]	L1 [mm]	L2 [mm]	L3 [mm]	L4 [mm]	W [mm]	X [mm]	Y [mm]	Z [mm]	feather key
Duplex-1 1/2" (double) for chains DIN 8187	70	258	89.0	150.0	259	74.5	168.9	240.9		B20x12x17
Duplex-1 1/2" (double) for chains DIN 8188	70	258	89.0	150.0	259	74.5	172.0	240.9		B20x12x17
Duplex-1 1/4" (double) for chains DIN 8187	60	233	62.5	151.5	234	64.0	160.8	215.4		B18x11x56
Duplex-1 1/4" (double) for chains DIN 8188	60	233	62.5	151.5	234	64.0	162.1	215.4		B18x11x56
Triple-1 1/4" (triple) for chains DIN 8187	70	258	89.0	150.0	259	74.5	162.3		253.4	B20x12x70
Triple-1 1/4" (triple) for chains DIN 8188	70	258	89.0	150.0	259	74.5	164.3		253.4	B20x12x70

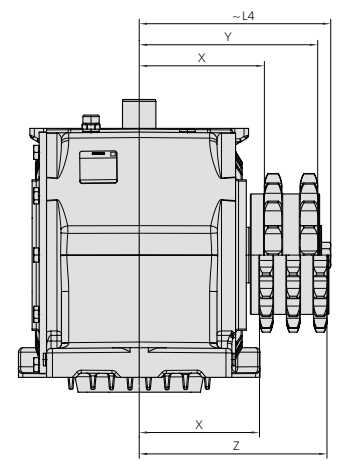

* Strength class of screws 10.9 | ** Specify mounting side of pinion or shaft end on order | *** Position of oil filling, breather, oil sensor and machine plate depend on output drive sides A and B

Type FTS 160.1

Performance

Transmission ratio 20.5

Lubrication Polyglycol
 Ambient temperature 40 °C
 Efficiency ≥ 91 %
 Max. output torque 4 kNm (according to EN 115 » safety factor ≥ 5)
 Max. radial force 32 kN (according to EN 115 » safety factor ≥ 5)

$\alpha = 60^\circ$
 $x = 194.5 \text{ mm}$

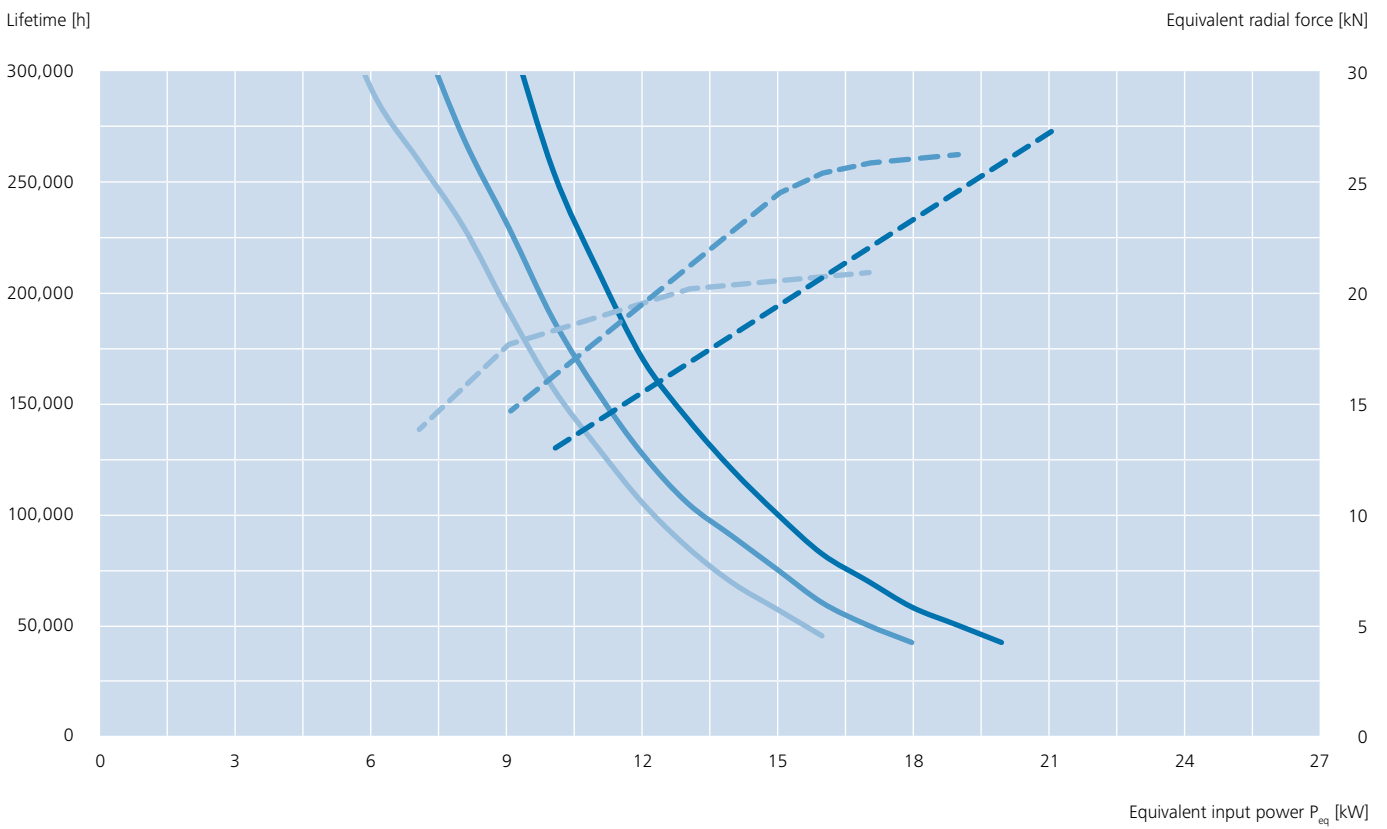

Lifetime	Radial force	Input speed [rpm]	Max. rated motor power [kW]	Max. rated radial force [kN]
—————	-----	980	19.0	32
—————	-----	1,180	22.0	32
—————	-----	1,480	22.0	29

The calculations of machine elements are based on the standards and guidelines reflecting the current state-of-the-art. Tooth profiles comply with the latest revision of DIN 3996:2012.

Performance

Type FTS 160.1

Transmission ratio 24.5

Lubrication	Polyglycol
Ambient temperature	40 °C
Efficiency	≥ 91 %
Max. output torque	4 kNm (according to EN 115 » safety factor ≥ 5)
Max. radial force	32 kN (according to EN 115 » safety factor ≥ 5)

$\alpha = 60^\circ$
 $x = 194.5 \text{ mm}$

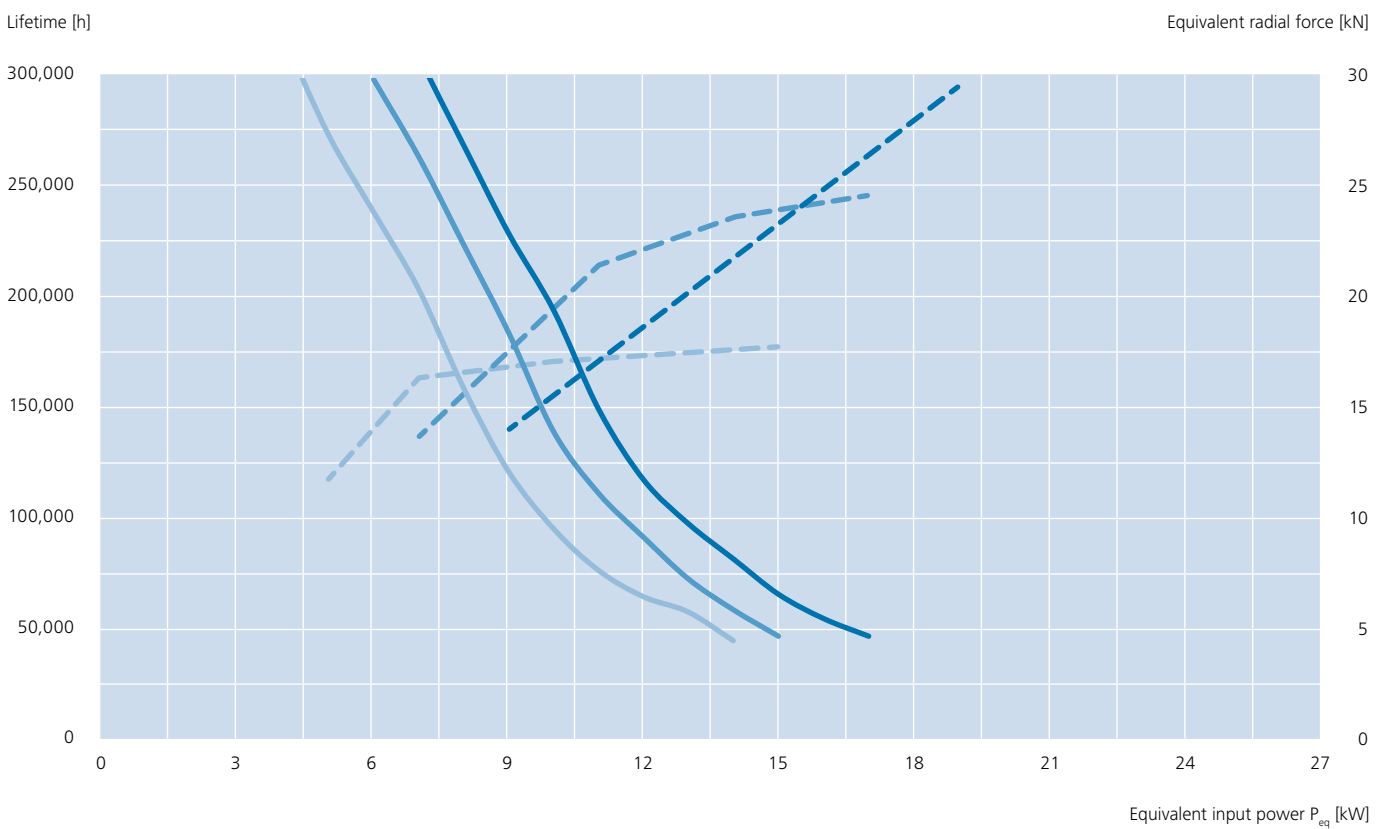

Lifetime	Radial force	Input speed [rpm]	Max. rated motor power [kW]	Max. rated radial force [kN]
—————	- - - - -	980	17.0	32
—————	- - - - -	1,180	19.0	32
—————	- - - - -	1,480	19.0	30

The calculations of machine elements are based on the standards and guidelines reflecting the current state-of-the-art. Tooth profiles comply with the latest revision of DIN 3996:2012.

For guaranteed ride comfort

AUMA Drives



Dimension Sheet

Type FTS 180.1

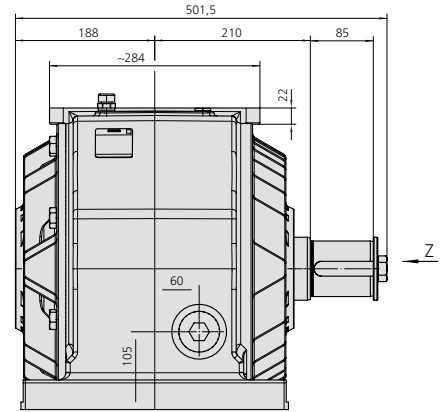
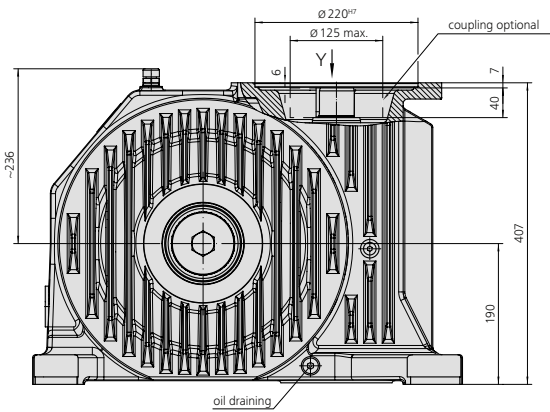
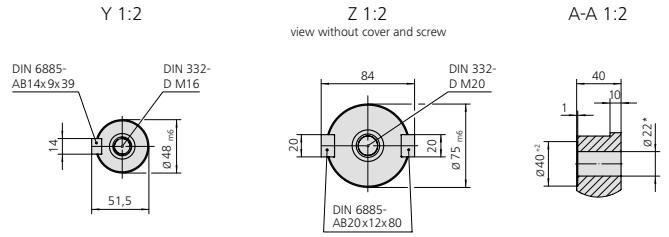
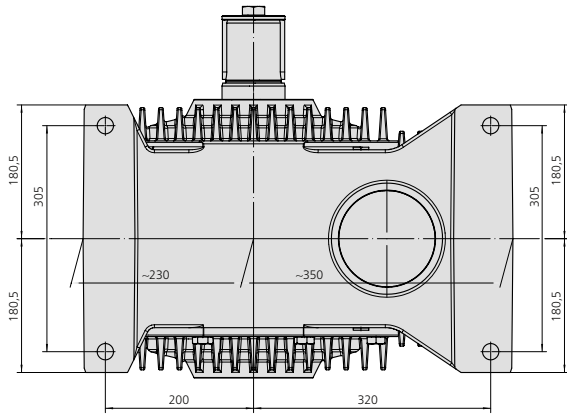

output side A

output side B

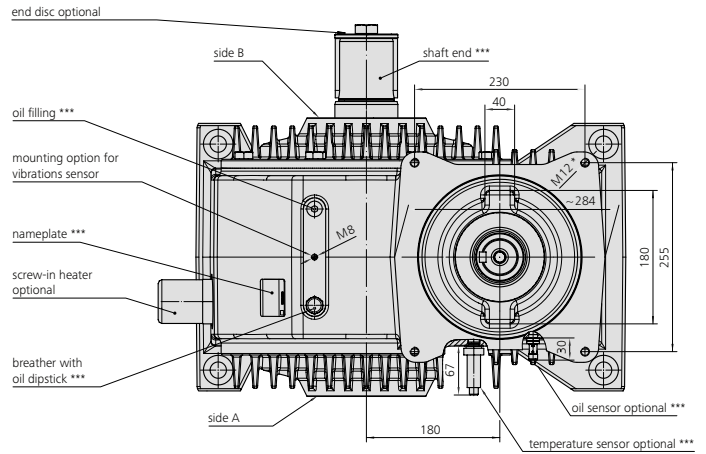
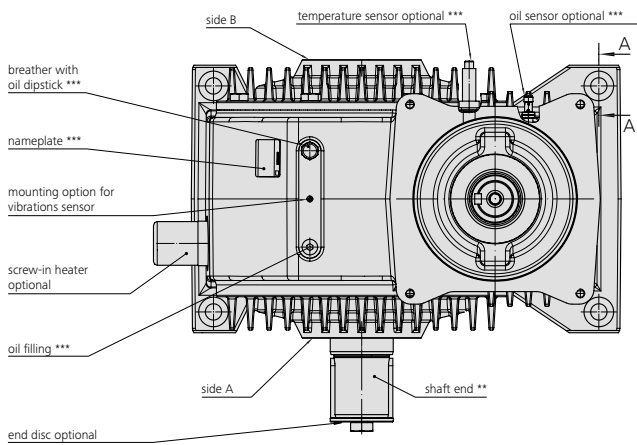

Pinion			
Type of pinion	X [mm]	Y [mm]	Z [mm]
Duplex-1 1/2" (double) for chains DIN 8187	228.9	300.9	
Duplex-1 1/2" (double) for chains DIN 8188	232.0	300.9	
Triple-1 1/4" (triple) for chains DIN 8187	222.3		313.4
Triple-1 1/4" (triple) for chains DIN 8188	224.5		313.4

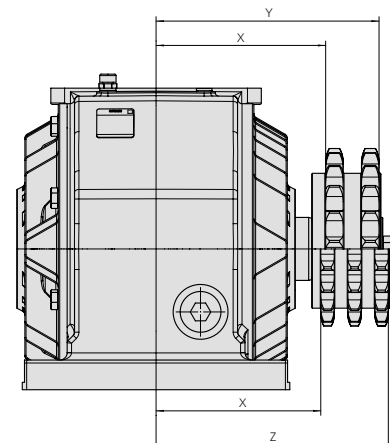

* Strength class of screws 10.9

** Specify mounting side of pinion or shaft end on order

*** Position of oil filling, breather, oil sensor and machine plate depend on output drive sides A and B

Type FTS 180.1

Performance

Transmission ratio 20.5

Lubrication Polyglycol
 Ambient temperature 40 °C
 Efficiency ≥ 92 %
 Max. output torque 4.4 kNm (according to EN 115 » safety factor ≥ 5)
 Max. radial force 44 kN (according to EN 115 » safety factor ≥ 5)

$\alpha = 60^\circ$
 $x = 252.5 \text{ mm}$

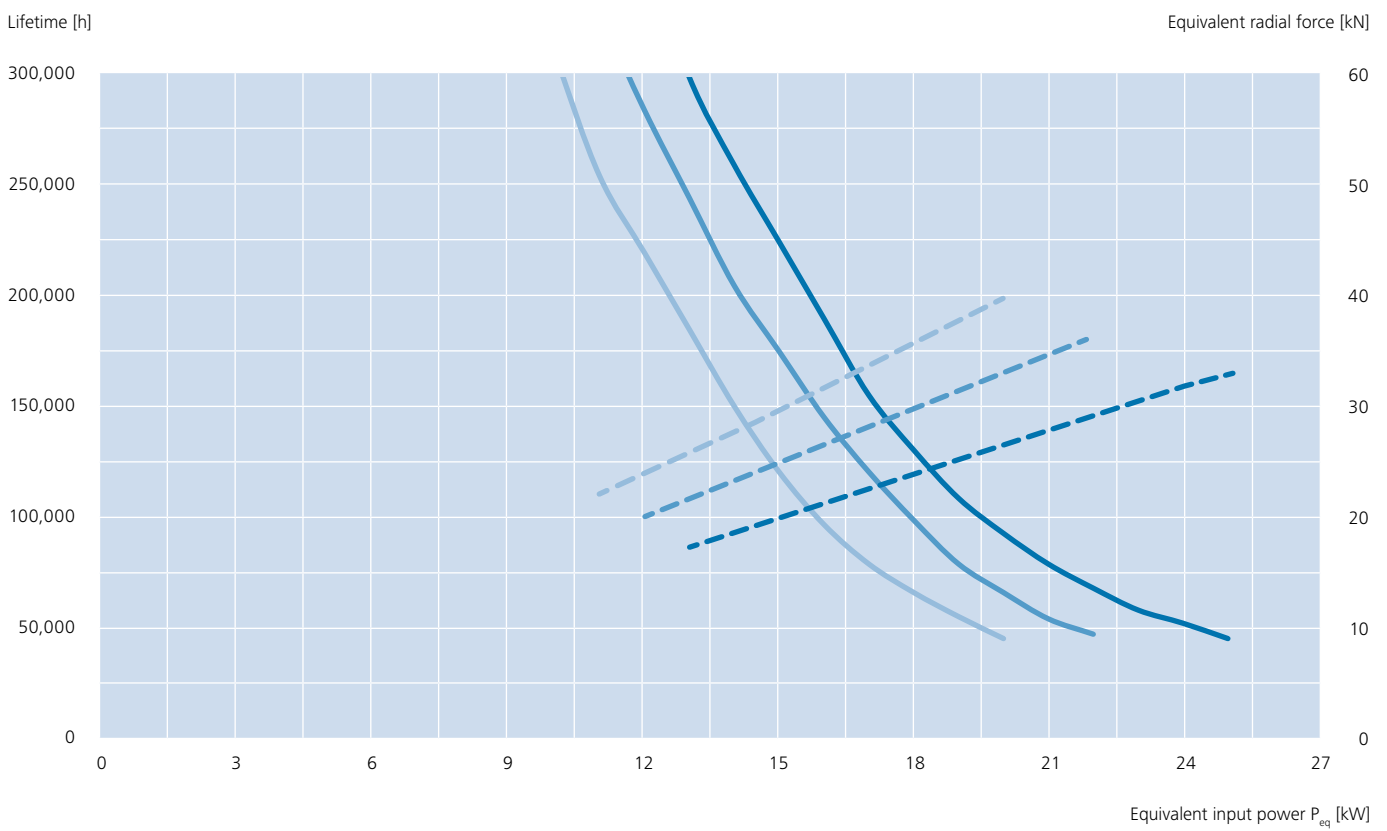

Lifetime	Radial force	Input speed [rpm]	Max. rated motor power [kW]	Max. rated radial force [kN]
—————	- - - - -	980	23.0	44
—————	- - - - -	1,180	25.0	42
—————	- - - - -	1,480	25.0	33

The calculations of machine elements are based on the standards and guidelines reflecting the current state-of-the-art. Tooth profiles comply with the latest revision of DIN 3996:2012.

Performance

Type FTS 180.1

Transmission ratio 24.5

Lubrication	Polyglycol	
Ambient temperature	40 °C	
Efficiency	≥ 92 %	
Max. output torque	4.4 kNm (according to EN 115 » safety factor ≥ 5)	$\alpha = 60^\circ$
Max. radial force	44 kN (according to EN 115 » safety factor ≥ 5)	$x = 252.5 \text{ mm}$

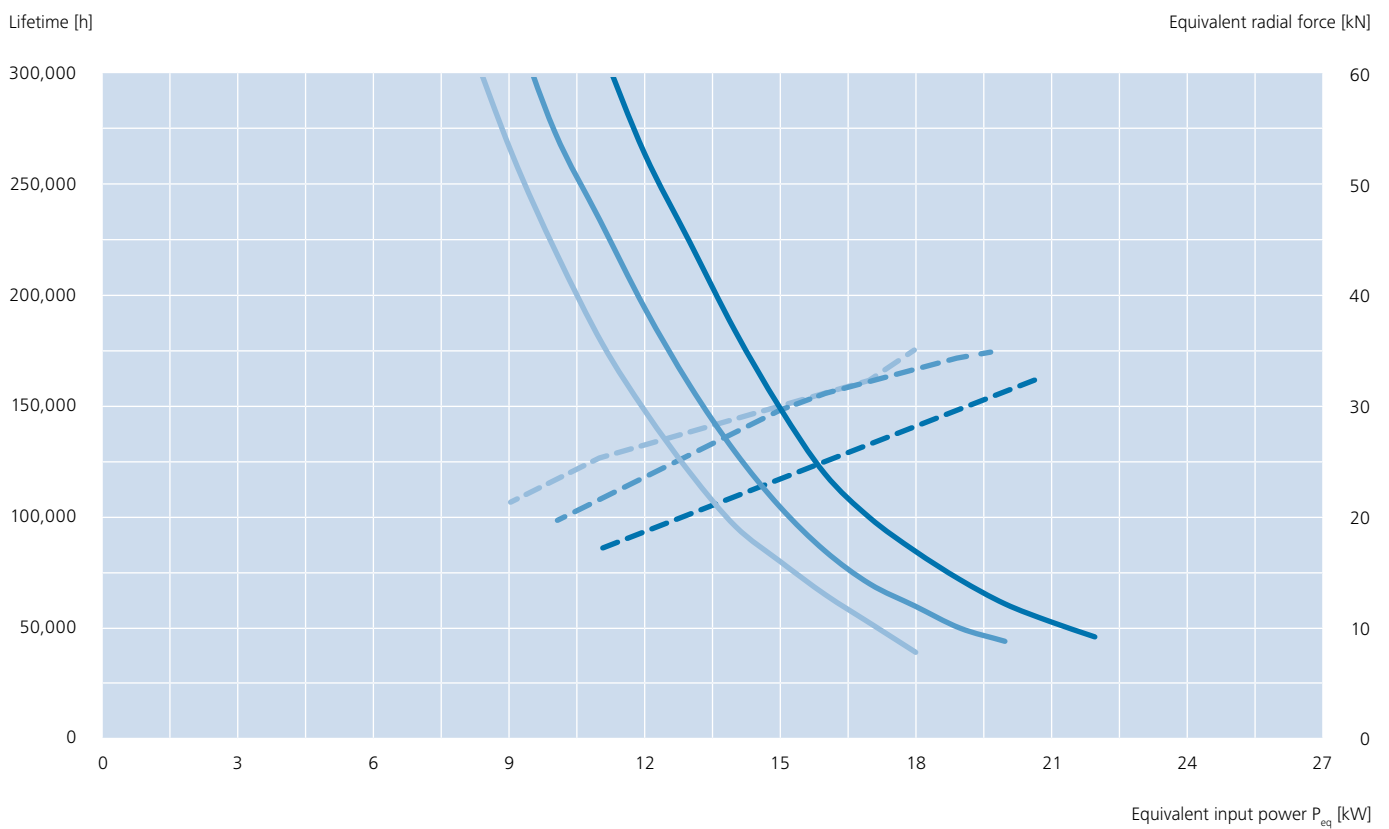

Lifetime	Radial force	Input speed [rpm]	Max. rated motor power [kW]	Max. rated radial force [kN]
—————	-----	980	22.0	44
—————	-----	1,180	22.0	44
—————	-----	1,480	24.0	38

The calculations of machine elements are based on the standards and guidelines reflecting the current state-of-the-art. Tooth profiles comply with the latest revision of DIN 3996:2012.



AUMA Drives noise measurement room

FTSST.1 Series

Worm-Helical-Gearbox

FTSST 158.1

FTSST 180.1

FTSST 212.1

FTSST 260.1

Design and Characteristics

Escalator gearboxes from the FTSST.1 series are high efficiency, two-stage gearboxes. They combine the advantages of worm gearboxes with the higher efficiency of helical gears. Vibration and shockabsorbing torque transmission, one of the main assets of worm gear units, means low-noise transport and therefore convenience for the passengers. Worm gearings with ZK type tooth profile optimized for this purpose have high overload capabilities and are therefore ideally suited for frequent load changes in daily operation. This is achieved by implementing grinded worm shafts made of case-hardened steel and worm wheels made of highly wear resistant special bronze. Worm

gearings correspond to DIN 3996:2012, the latest method for calculation of load capacity. The load capacity for the spur gear stages have been calculated according to DIN 3990. All machine elements within AUMA Drives escalator gear units meet the safety factor ≥ 5 according to EN 115:2010. FEM optimized housings warrant for maximum stiffness and consequently reduced vibration within the powertrain. Four sizes, each with three gear ratios, cover the power range from 10 to 75 kW.

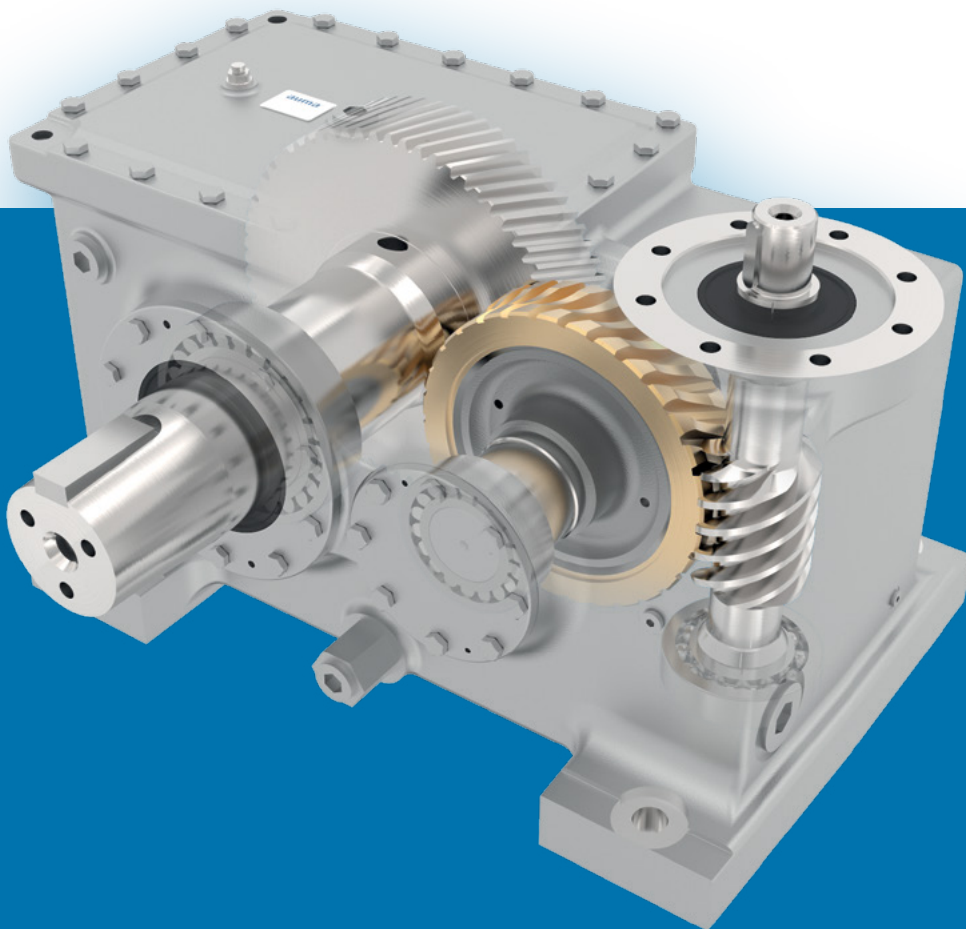
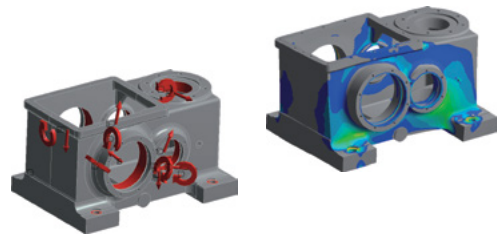

Noise emission, efficiency and lifetime

With regard to low-noise applications and noise emissions, worm gear units will always be the measure of all things. In combination with the gear-optimized spur gear stage, the FTSST.1 series is the benchmark for efficiency and smooth running. In our in-house acoustic measurement room complying with DIN standards, the acoustic pressure level of our escalator gear units is measured and recorded as part of final inspection. Machining of gear sets on state-of-the-art equipment as well as unique measuring technology, partially in special development projects in close cooperation with our partners, ensure optimum gear quality. When using synthetic polyglycol lubricants the FTSST.1 series achieve an efficiency rating of up to 95% thanks to our gearing optimisation technology. Paired with the implementation

of top grade materials, selected standard parts and high precision housing machining, maximum service life and highest reliability are achieved. The evidence of these results were confirmed by internal verifications and tests on customers' test benches.

Options and mounting parts

If specifically desired, AUMA Drives escalator gear units can be provided with integrated sensor technology for monitoring oil level, oil sump temperature and system vibration. When implemented in extremely low temperature environments, we offer an optional oil heater to ensure optimum lubrication as early as during the start-up phase.

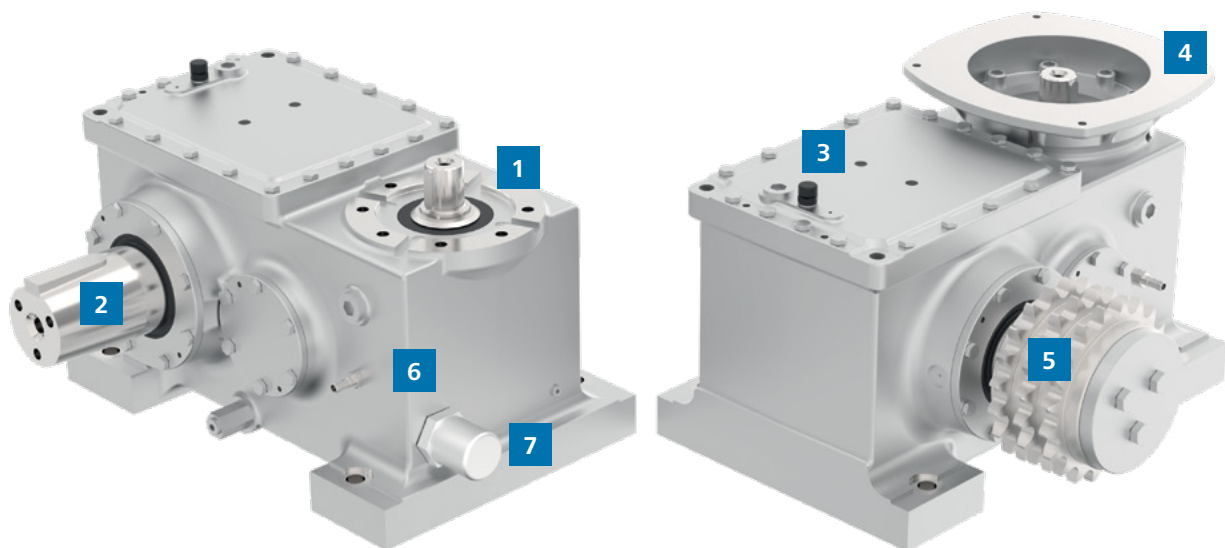

1 Input shaft

2 Output shaft

3 Air breather

4 Motor flange [option]

5 Chain pinion / sprocket [option]

6 Oil sensor (temperature and level) [option]

7 Oil heater [option]

For an extra level of convenience

AUMA Drives



Type FTSST 158.1

Performance

Transmission ratio 20.4

Lubrication	Polyglycol	
Ambient temperature	40 °C	
Efficiency	up to 94 %	
Max. output torque	4.6 kNm (according to EN 115 » safety factor ≥ 5)	$\alpha = 0 \dots 60^\circ$
Max. radial force	50 kN (according to EN 115 » safety factor ≥ 5)	$x = 255 \text{ mm}$

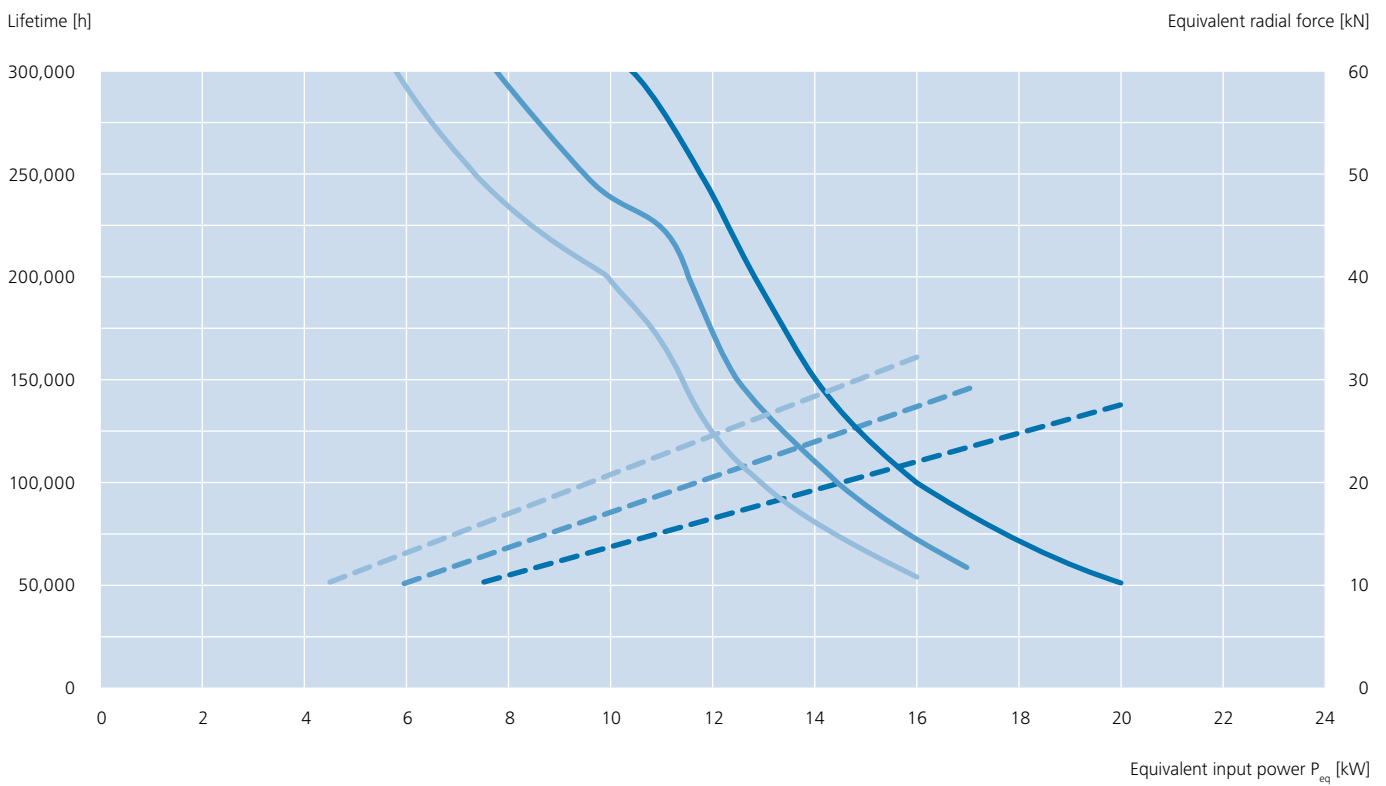
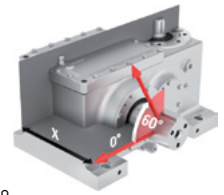

Lifetime	Radial force	Input speed [rpm]	Max. rated motor power [kW]	Max. rated radial force [kN]
—————	- - - - -	980	18.6	38
—————	- - - - -	1,180	20.0	34
—————	- - - - -	1,480	22.0	30

The calculations of machine elements are based on the standards and guidelines reflecting the current state-of-the-art. Tooth profiles comply with the latest revision of DIN 3996:2012 and ISO 6336:2006.

Performance

Type FTSST 158.1

Transmission ratio 26.0

Lubrication	Polyglycol	
Ambient temperature	40 °C	
Efficiency	up to 94 %	
Max. output torque	4.6 kNm (according to EN 115 » safety factor ≥ 5)	$\alpha = 0 \dots 60^\circ$
Max. radial force	50 kN (according to EN 115 » safety factor ≥ 5)	$x = 255 \text{ mm}$

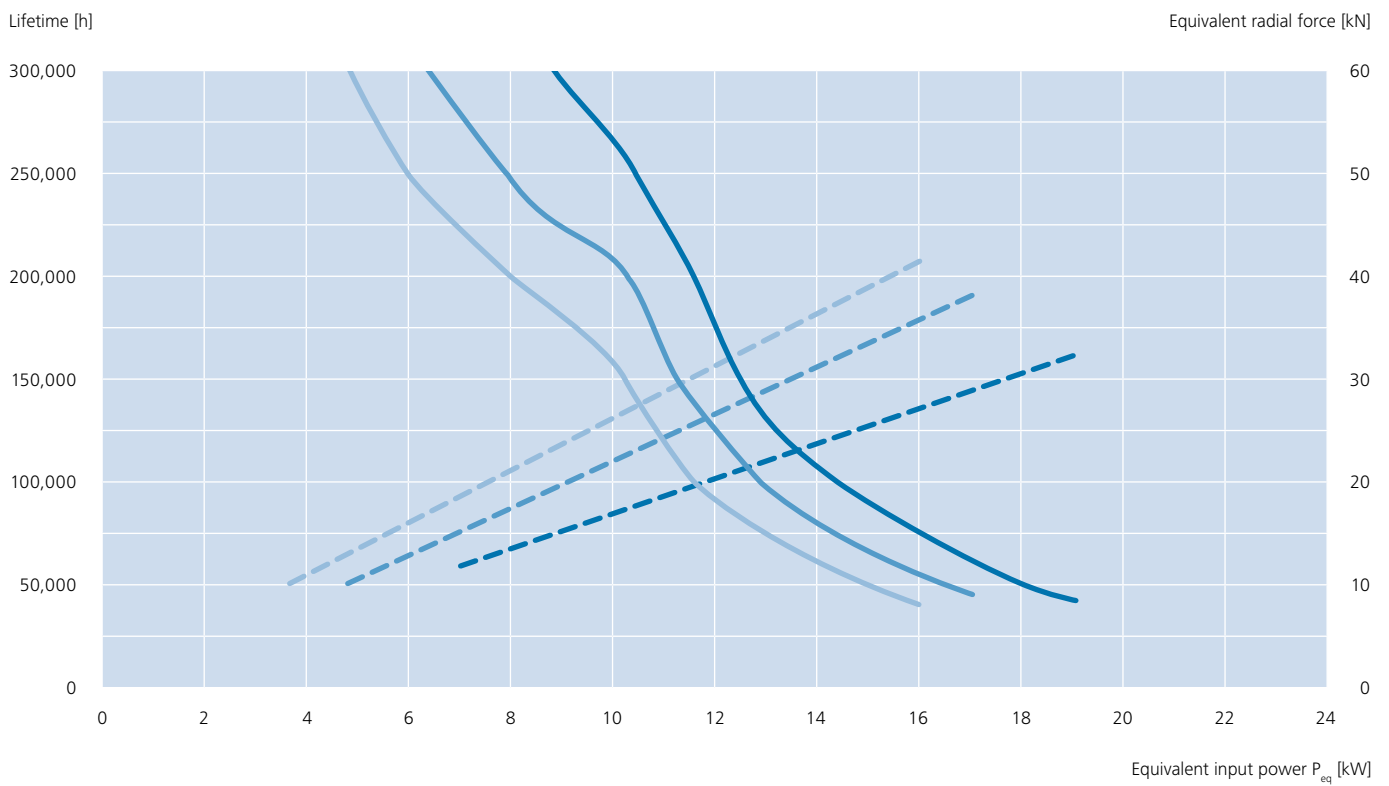
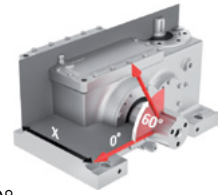

Lifetime	Radial force	Input speed [rpm]	Max. rated motor power [kW]	Max. rated radial force [kN]
—————	- - - - -	980	16.0	42
—————	- - - - -	1,180	18.6	40
—————	- - - - -	1,480	22.0	38

The calculations of machine elements are based on the standards and guidelines reflecting the current state-of-the-art. Tooth profiles comply with the latest revision of DIN 3996:2012 and ISO 6336:2006.

Type FTSST 158.1

Performance

Transmission ratio 32.5

Lubrication Polyglycol
 Ambient temperature 40 °C
 Efficiency up to 94 %
 Max. output torque 4.6 kNm (according to EN 115 » safety factor ≥ 5)
 Max. radial force 50 kN (according to EN 115 » safety factor ≥ 5)

$\alpha = 0 \dots 60^\circ$
 $x = 255 \text{ mm}$

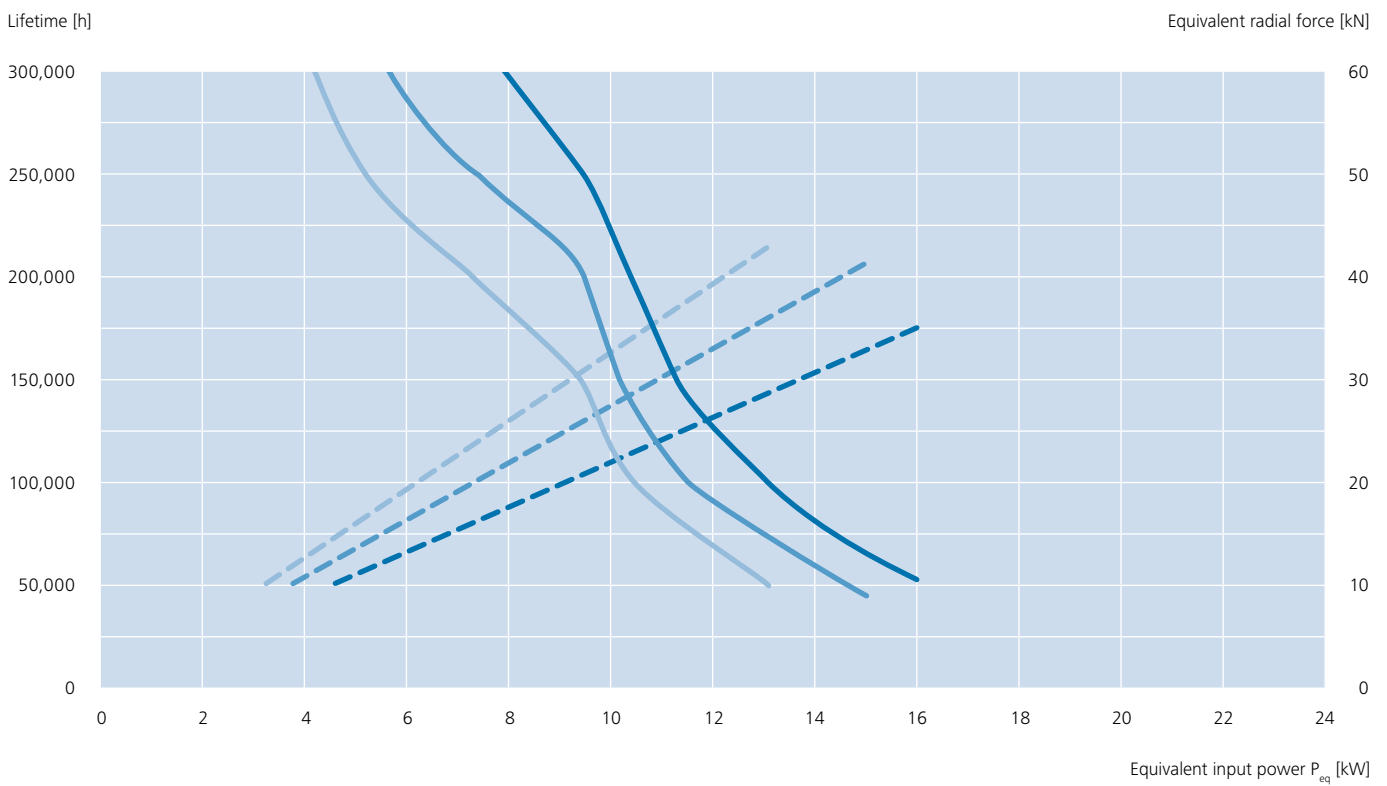
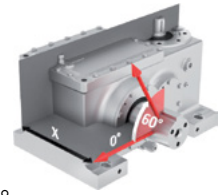

Lifetime	Radial force	Input speed [rpm]	Max. rated motor power [kW]	Max. rated radial force [kN]
—————	- - - - -	980	13.0	43
—————	- - - - -	1,180	15.0	41
—————	- - - - -	1,480	18.6	40

The calculations of machine elements are based on the standards and guidelines reflecting the current state-of-the-art. Tooth profiles comply with the latest revision of DIN 3996:2012 and ISO 6336:2006.

Only top grade materials

AUMA Drives

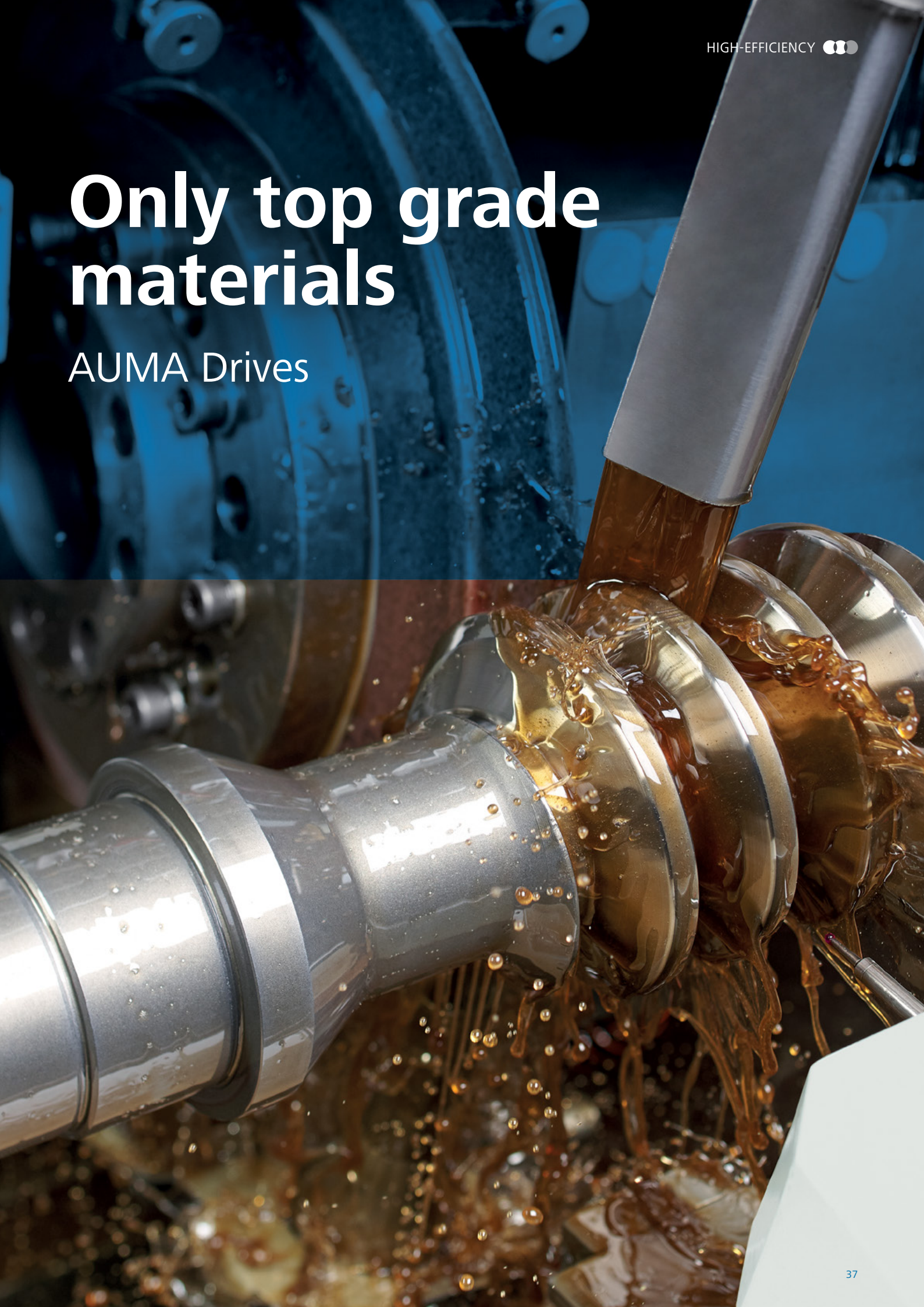

Performance

Type FTSST 180.1

Transmission ratio 20.4

Lubrication	Polyglycol	
Ambient temperature	40 °C	
Efficiency	up to 94 %	
Max. output torque	6.5 kNm (according to EN 115 » safety factor ≥ 5)	$\alpha = 0 \dots 60^\circ$
Max. radial force	71 kN (according to EN 115 » safety factor ≥ 5)	$x = 300 \text{ mm}$

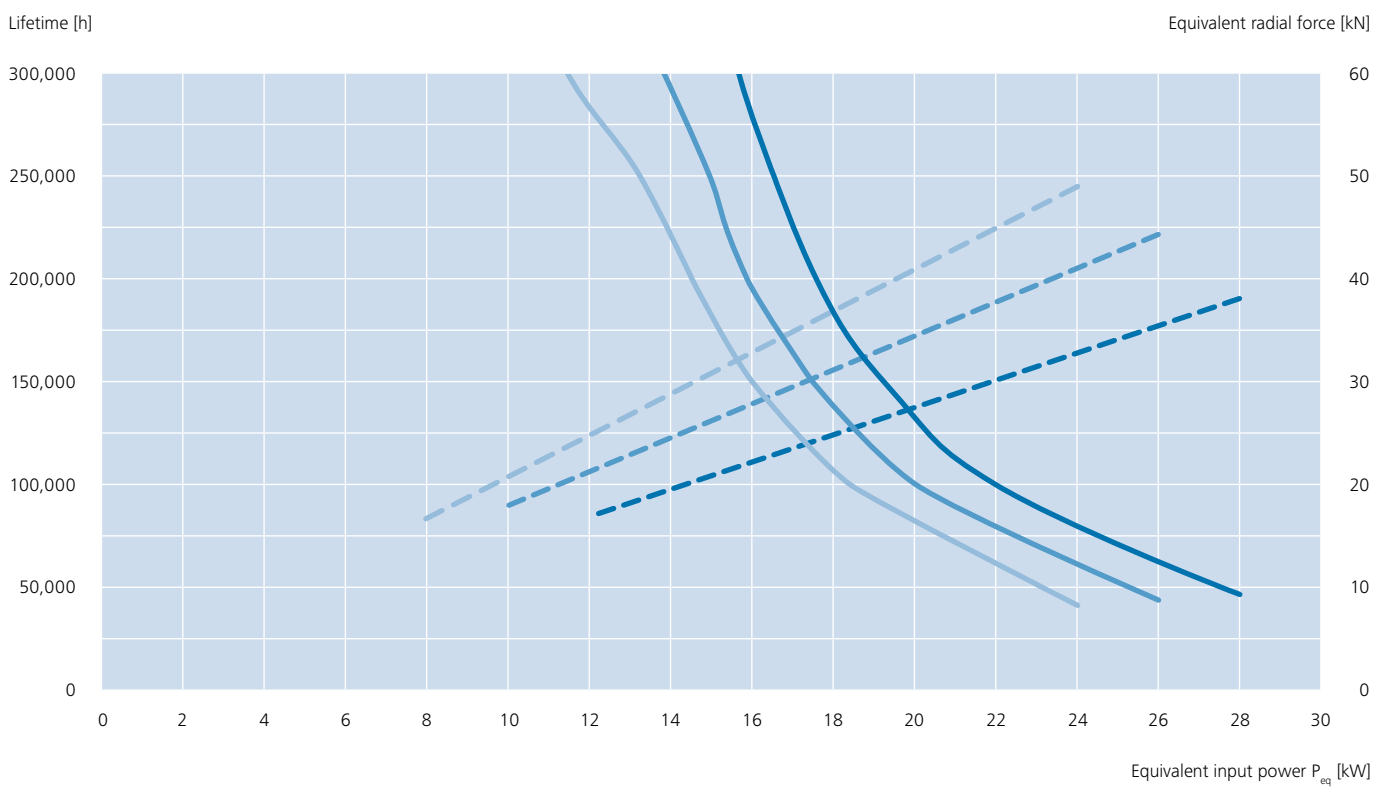
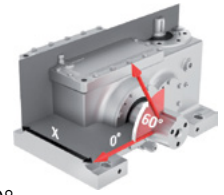

Lifetime	Radial force	Input speed [rpm]	Max. rated motor power [kW]	Max. rated radial force [kN]
—————	-----	980	30.0	61
—————	-----	1,180	30.0	51
—————	-----	1,480	30.0	41

The calculations of machine elements are based on the standards and guidelines reflecting the current state-of-the-art. Tooth profiles comply with the latest revision of DIN 3996:2012 and ISO 6336:2006.

Type FTSST 180.1

Performance

Transmission ratio 26.6

Lubrication	Polyglycol	
Ambient temperature	40 °C	
Efficiency	up to 94 %	
Max. output torque	6.5 kNm (according to EN 115 » safety factor ≥ 5)	$\alpha = 0 \dots 60^\circ$
Max. radial force	71 kN (according to EN 115 » safety factor ≥ 5)	$x = 300 \text{ mm}$

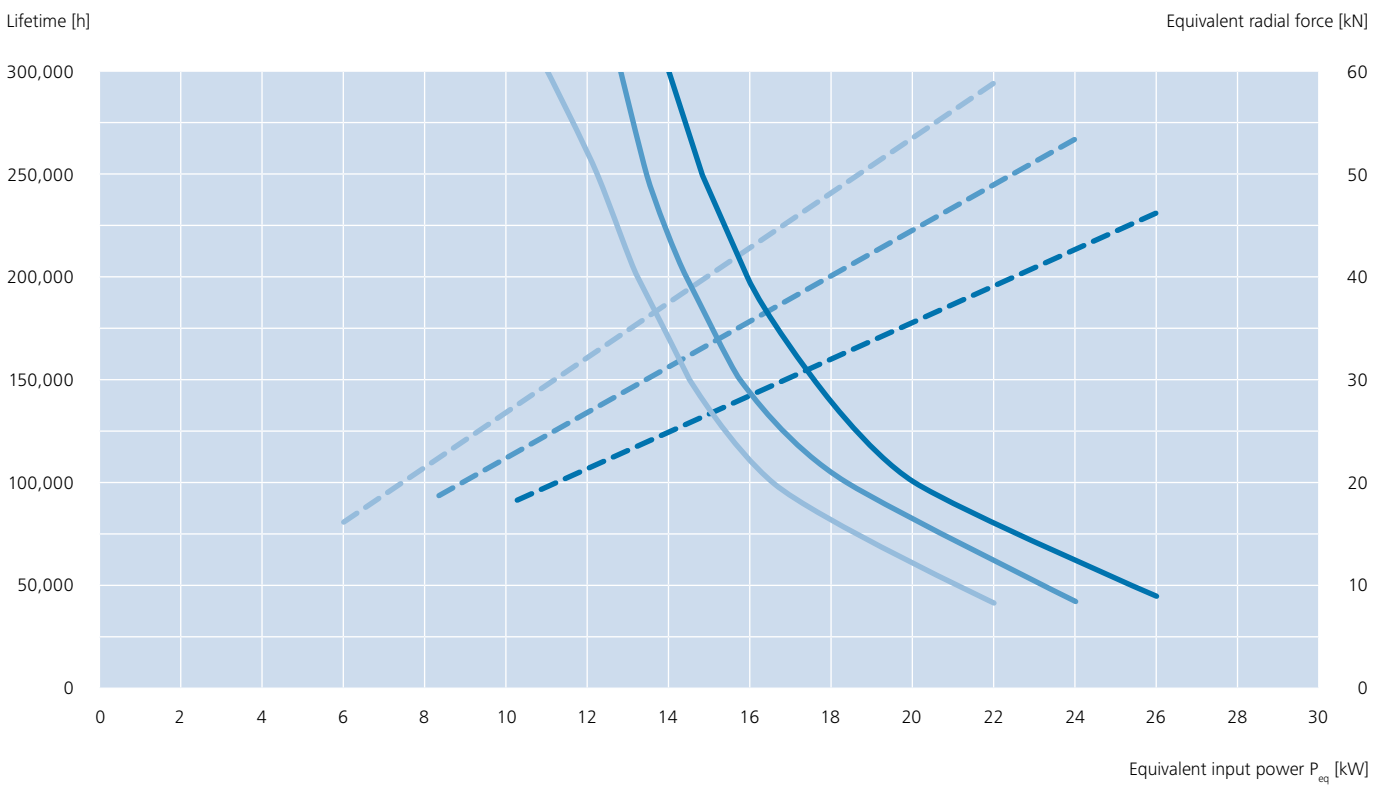
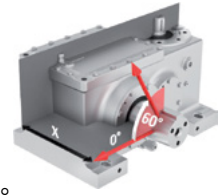

Lifetime	Radial force	Input speed [rpm]	Max. rated motor power [kW]	Max. rated radial force [kN]
—————	- - - - -	980	27.0	58
—————	- - - - -	1,180	30.0	67
—————	- - - - -	1,480	30.0	53

The calculations of machine elements are based on the standards and guidelines reflecting the current state-of-the-art. Tooth profiles comply with the latest revision of DIN 3996:2012 and ISO 6336:2006.

Performance

Type FTSST 180.1

Transmission ratio 32.8

Lubrication	Polyglycol	
Ambient temperature	40 °C	
Efficiency	up to 94 %	
Max. output torque	6.5 kNm (according to EN 115 » safety factor ≥ 5)	$\alpha = 0 \dots 60^\circ$
Max. radial force	71 kN (according to EN 115 » safety factor ≥ 5)	$x = 300 \text{ mm}$

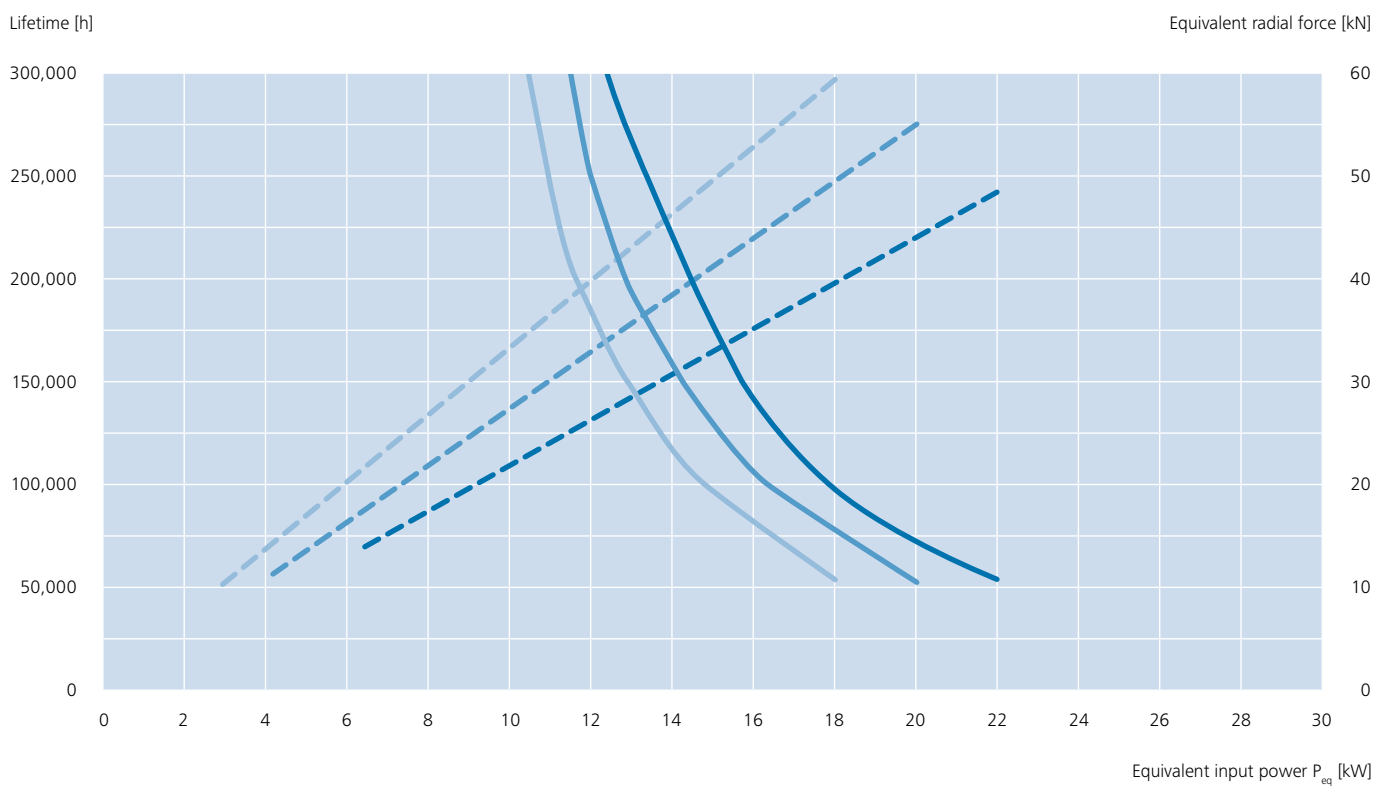
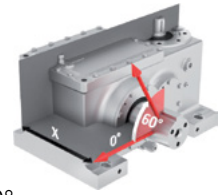

Lifetime	Radial force	Input speed [rpm]	Max. rated motor power [kW]	Max. rated radial force [kN]
—————	- - - - -	980	21.0	58
—————	- - - - -	1,180	26.0	57
—————	- - - - -	1,480	30.0	66

Committed to the highest quality

Quality management at AUMA Drives has many facets. From the beginning of the development phase, it consistently runs through the entire production process all the way to assembly at the customer's site. Accordingly, the objective is ambitious: to achieve optimal gearbox quality in all drive systems throughout their entire lifecycle.

Clearly defined processes are a key pillar of AUMA Drives' quality concept. Ongoing analyses of potential faults or influencing factors shape the standard procedures in quality assurance, as do capability assessments for machines and precisely documented manufacturing processes and testing methods. As a result, every production step can be thoroughly traced: all components of the gearboxes and drive systems

from Coswig are fully traceable – in most cases even back to the supplier and manufacturer of the raw materials.

Most of the test rigs at AUMA Drives' test center are in-house developments. They enable the collection of a wide range of application-specific parameters, depending on customer requirements. Supplier components undergo the same testing cycle as complete gearbox units – sometimes even under extreme environmental conditions. For example, the rolling bearing test bench can simulate 400,000 operating hours under normal load. In the climate chamber, gearboxes can be tested at temperatures as low as -40 degrees Celsius. Additional test systems include torque and vibration test benches, fracture resistance testing equipment, and many more.

Do you want to learn more?

Visit our website and explore more details of various processes that shaped more than 100 years of our company history.

www.auma-drives.com



When it needs to last a lifetime

AUMA Drives

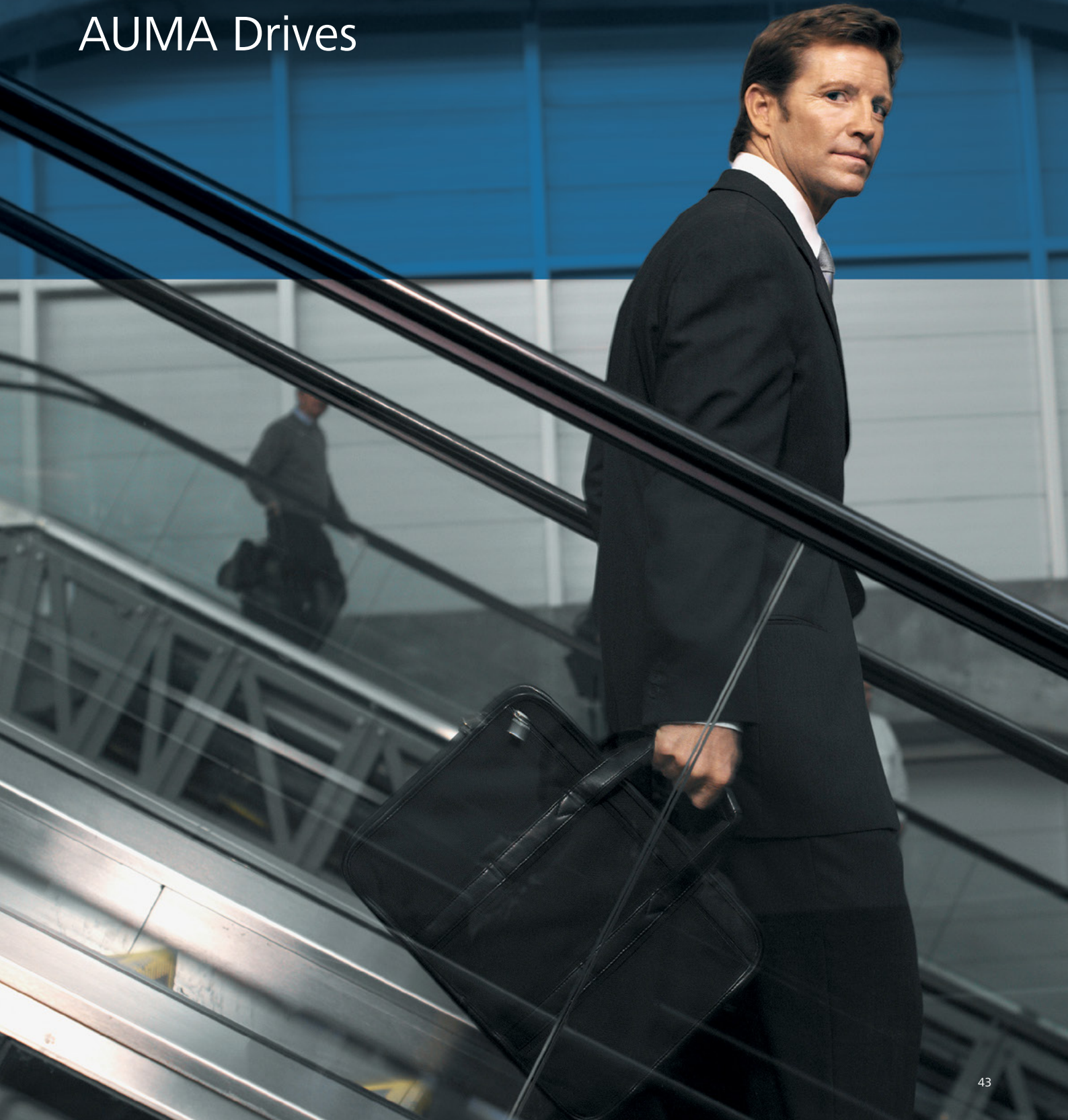

Performance

Type FTSST 212.1

Transmission ratio 20.1

Lubrication	Polyglycol	
Ambient temperature	40 °C	
Efficiency	up to 94 %	
Max. output torque	12.2 kNm (according to EN 115 » safety factor ≥ 5)	$\alpha = 0 \dots 60^\circ$
Max. radial force	100 kN (according to EN 115 » safety factor ≥ 5)	$x = 305 \text{ mm}$

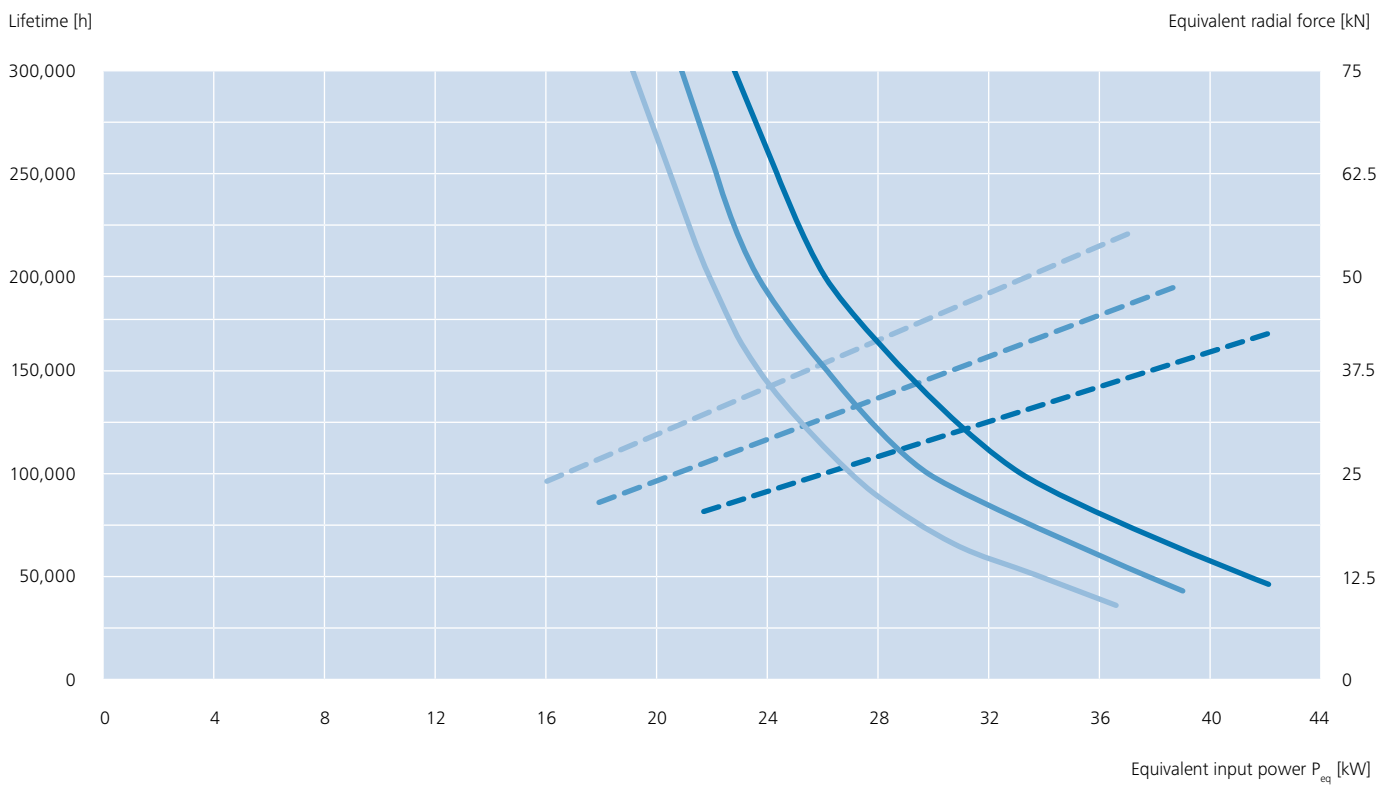
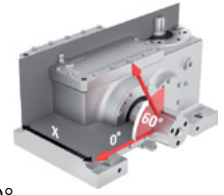

Lifetime	Radial force	Input speed [rpm]	Max. rated motor power [kW]	Max. rated radial force [kN]
—————	- - - - -	980	42.0	63
—————	- - - - -	1,180	45.0	56
—————	- - - - -	1,480	45.0	45

The calculations of machine elements are based on the standards and guidelines reflecting the current state-of-the-art. Tooth profiles comply with the latest revision of DIN 3996:2012 and ISO 6336:2006.

Type FTSST 212.1

Performance

Transmission ratio 25.7

Lubrication Polyglycol

Ambient temperature

40 °C

Efficiency

up to 94 %

Max. output torque

12.2 kNm (according to EN 115 » safety factor ≥ 5)

$\alpha = 0 \dots 60^\circ$

Max. radial force

100 kN (according to EN 115 » safety factor ≥ 5)

$x = 305 \text{ mm}$

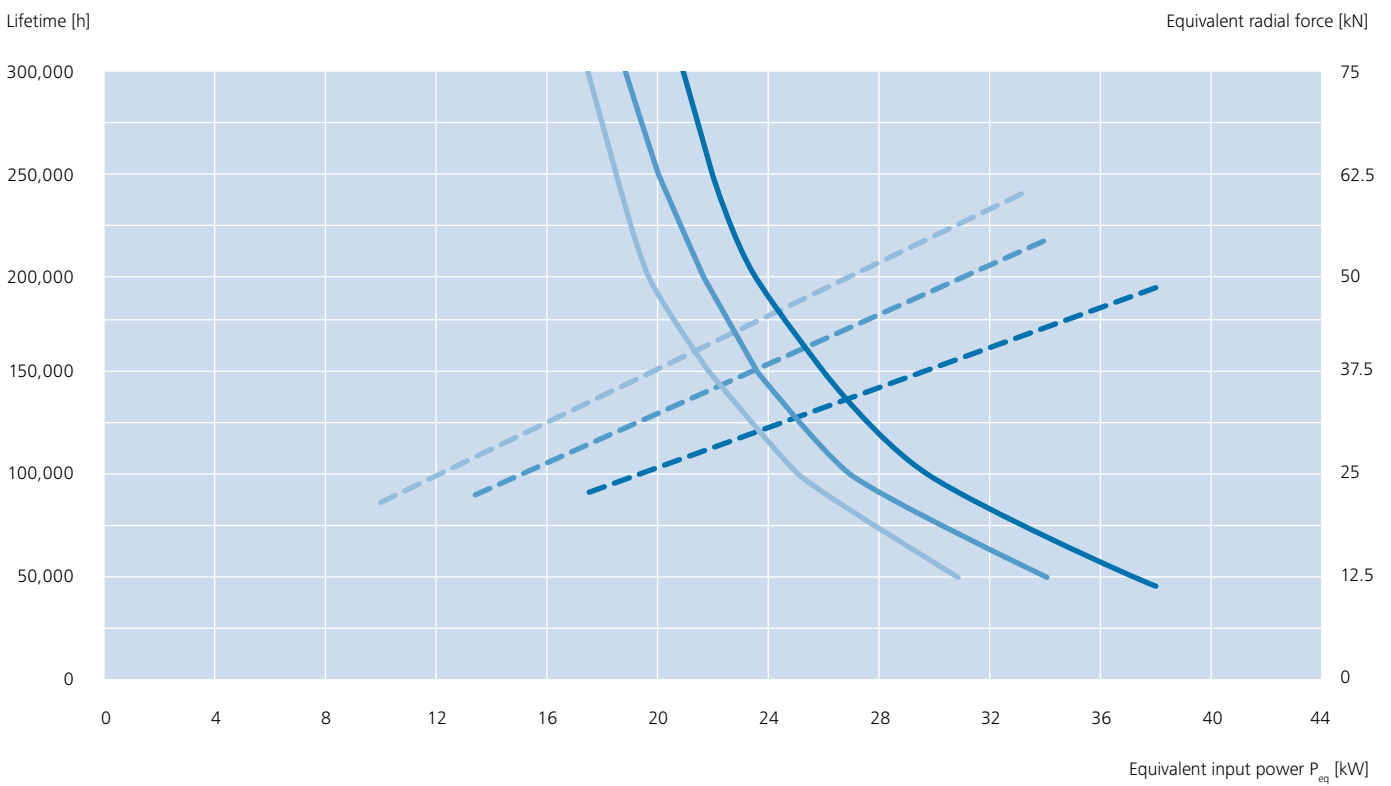
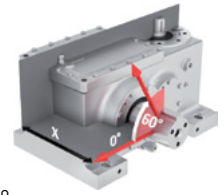

Lifetime	Radial force	Input speed [rpm]	Max. rated motor power [kW]	Max. rated radial force [kN]
—————	-----	980	40.0	77
—————	-----	1,180	42.0	67
—————	-----	1,480	45.0	58

The calculations of machine elements are based on the standards and guidelines reflecting the current state-of-the-art. Tooth profiles comply with the latest revision of DIN 3996:2012 and ISO 6336:2006.

Performance

Type FTSST 212.1

Transmission ratio 32.1

Lubrication	Polyglycol	
Ambient temperature	40 °C	
Efficiency	up to 94 %	
Max. output torque	12.2 kNm (according to EN 115 » safety factor ≥ 5)	$\alpha = 0 \dots 60^\circ$
Max. radial force	100 kN (according to EN 115 » safety factor ≥ 5)	$x = 305 \text{ mm}$

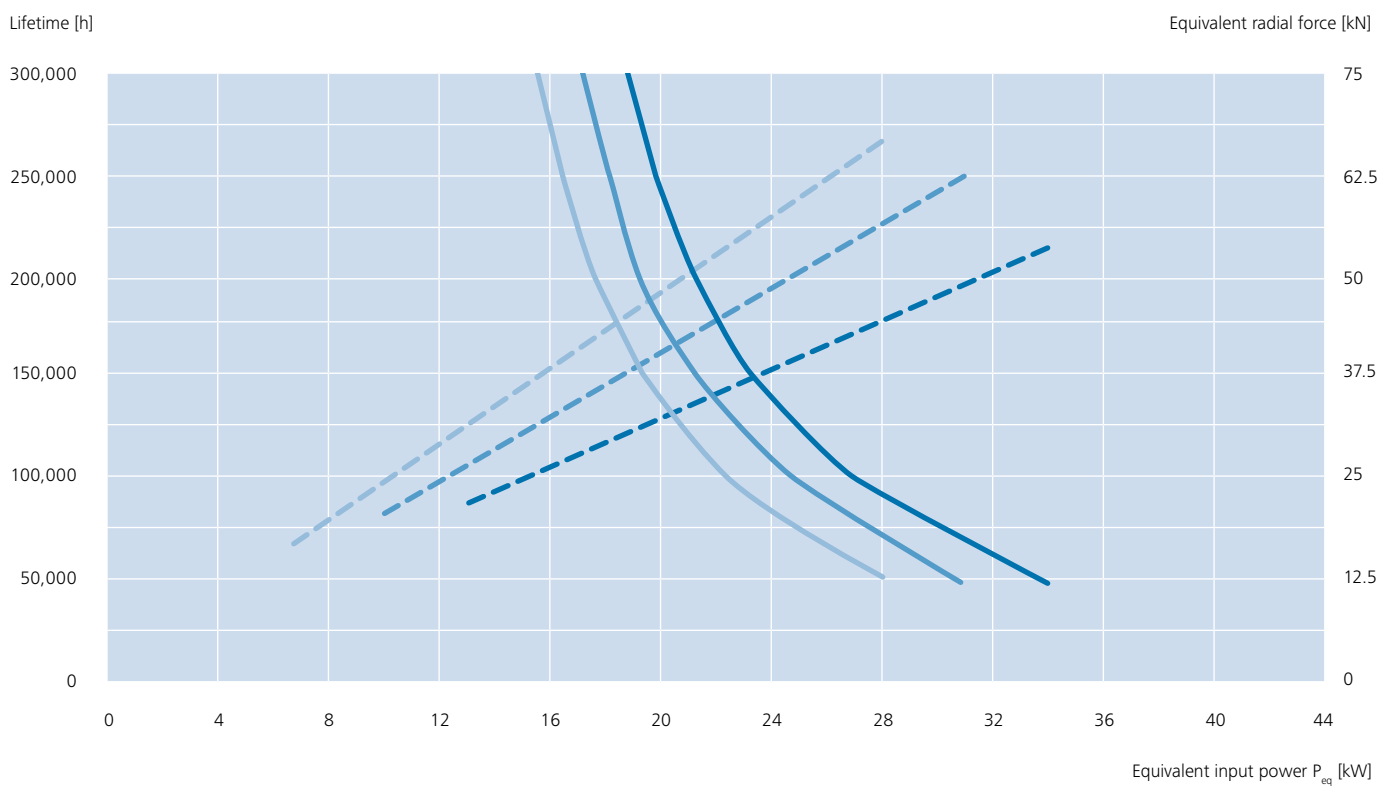
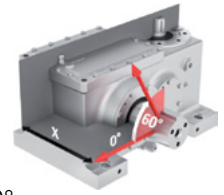

Lifetime	Radial force	Input speed [rpm]	Max. rated motor power [kW]	Max. rated radial force [kN]
—————	- - - - -	980	36.0	87
—————	- - - - -	1,180	39.0	78
—————	- - - - -	1,480	42.0	67

Vibration-free transport

AUMA Drives



Type FTSST 260.1

Performance

Transmission ratio 26.3

Lubrication	Polyglycol	
Ambient temperature	40 °C	
Efficiency	≥ 96 %	
Max. output torque	20 kNm (according to EN 115 » safety factor = 5)	$\alpha = 0 \dots 60^\circ$
Max. radial force	135 kN (according to EN 115 » safety factor = 5)	$x = 360 \text{ mm}$

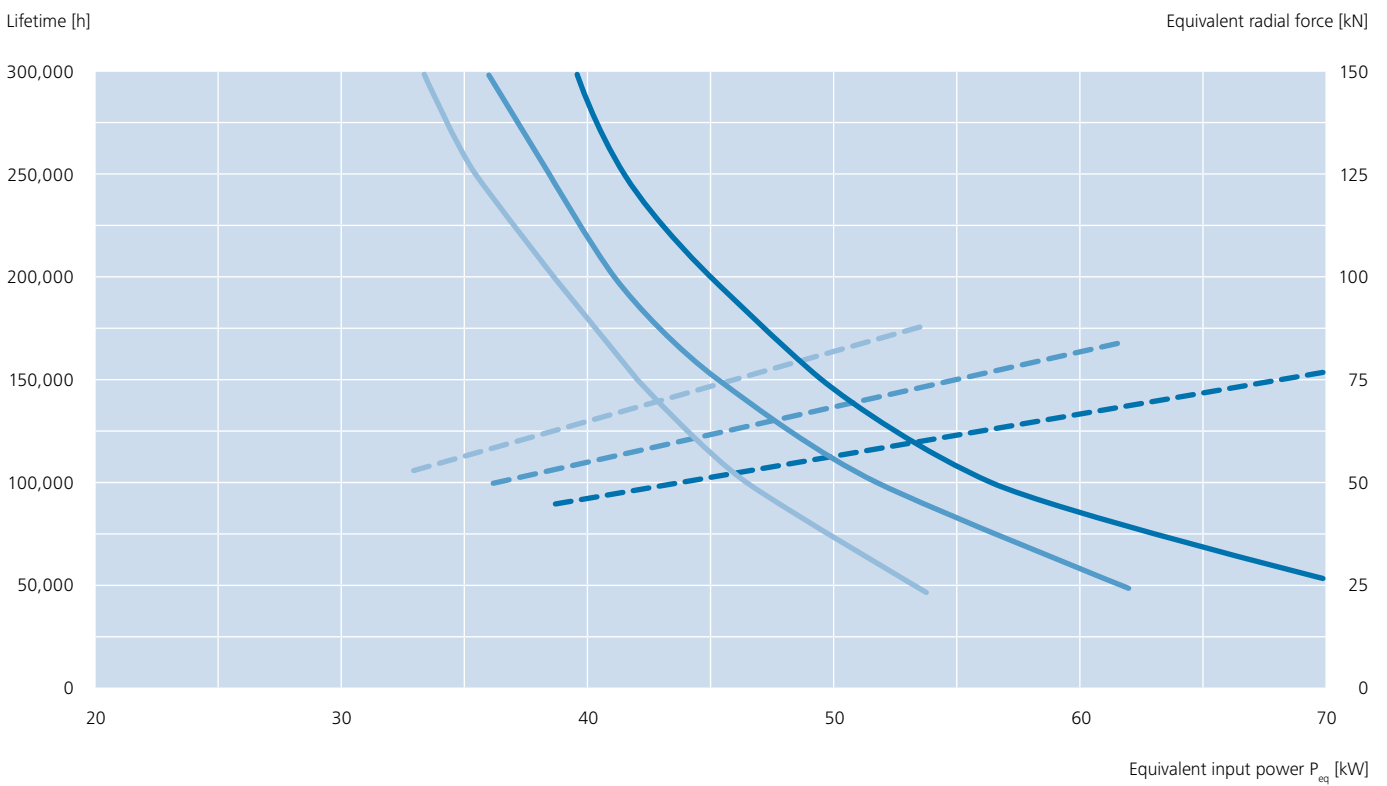
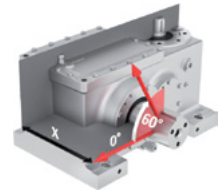

Lifetime	Radial force	Input speed [rpm]	Max. rated motor power [kW]	Max. rated radial force [kN]
—————	- - - - -	980	65.0	106
—————	- - - - -	1,180	75.0	102
—————	- - - - -	1,480	75.0	81

The calculations of machine elements are based on the standards and guidelines reflecting the current state-of-the-art. Tooth profiles comply with the latest revision of DIN 3996:2012.

Performance

Type FTSST 260.1

Transmission ratio 33.5

Lubrication	Polyglycol	
Ambient temperature	40 °C	
Efficiency	≥ 96 %	
Max. output torque	20 kNm (according to EN 115 » safety factor = 5)	$\alpha = 0 \dots 60^\circ$
Max. radial force	135 kN (according to EN 115 » safety factor = 5)	$x = 360 \text{ mm}$

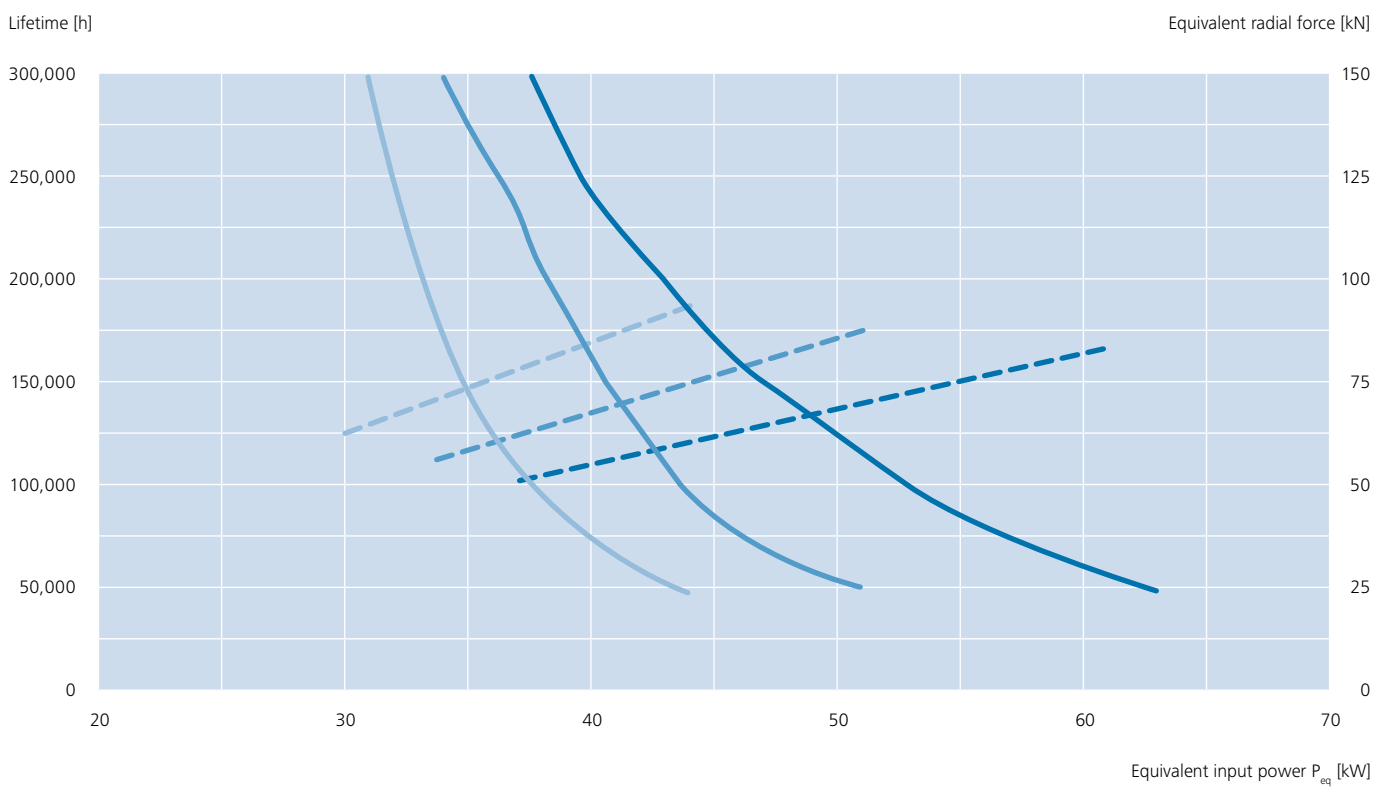
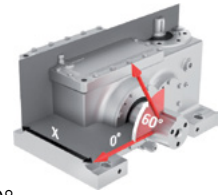

Lifetime	Radial force	Input speed [rpm]	Max. rated motor power [kW]	Max. rated radial force [kN]
—————	- - - - -	980	44.0	91
—————	- - - - -	1,180	63.0	108
—————	- - - - -	1,480	75.0	103

The calculations of machine elements are based on the standards and guidelines reflecting the current state-of-the-art. Tooth profiles comply with the latest revision of DIN 3996:2012.



Gleason

BLADE SCREW TORQUE
21 FT. LBS.

PENTAC-EM

KEYWAY

GLEASON U.S.A.
SERIAL
61468

CENTER CLAMP BOLT
TORQUE 14 FT. LBS.

SOCKET TO
TIGHTEN TO
MACHINE FORMING

HYMAX FTHST.1 Series

Hypoid-Helical-Gearbox

FTHST 156.1

FTHST 168.1

FTHST 182.1

Design and Characteristics

Various outstanding features have established our HYMAX gear units as first class escalator gear units. The latest state of research has been implemented in the drive design, which is consistently geared to maximum efficiency. Without compromise, the experience gained from more than 20 years of developing escalator gear units has been transferred into a design that sets new standards. FEM optimised housings warrant for maximum stiffness and consequently reduced vibration within the powertrain.

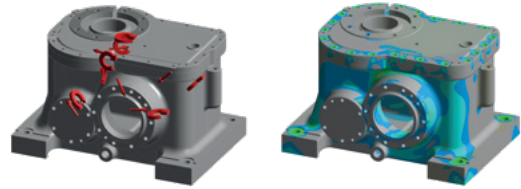

Component	Code
Geared elements and shafts	Unlimited nominal fatigue life EN 115: 2017 -Chapter 5.4.1.3.2.
Housing	Guideline FKM (6th edition)
Hypoid gear sets	ISO 10300 (2014)
Helical gear sets	ISO 6336 (2006)
Shafts	DIN 743 (2012)
Feather keys	DIN 6892 (2012 method B)
Bearings	ISO/TS 16281 (2008)
Joins	Form-locked only EN 115:2017 - Chapter 5.4.1.3.1.

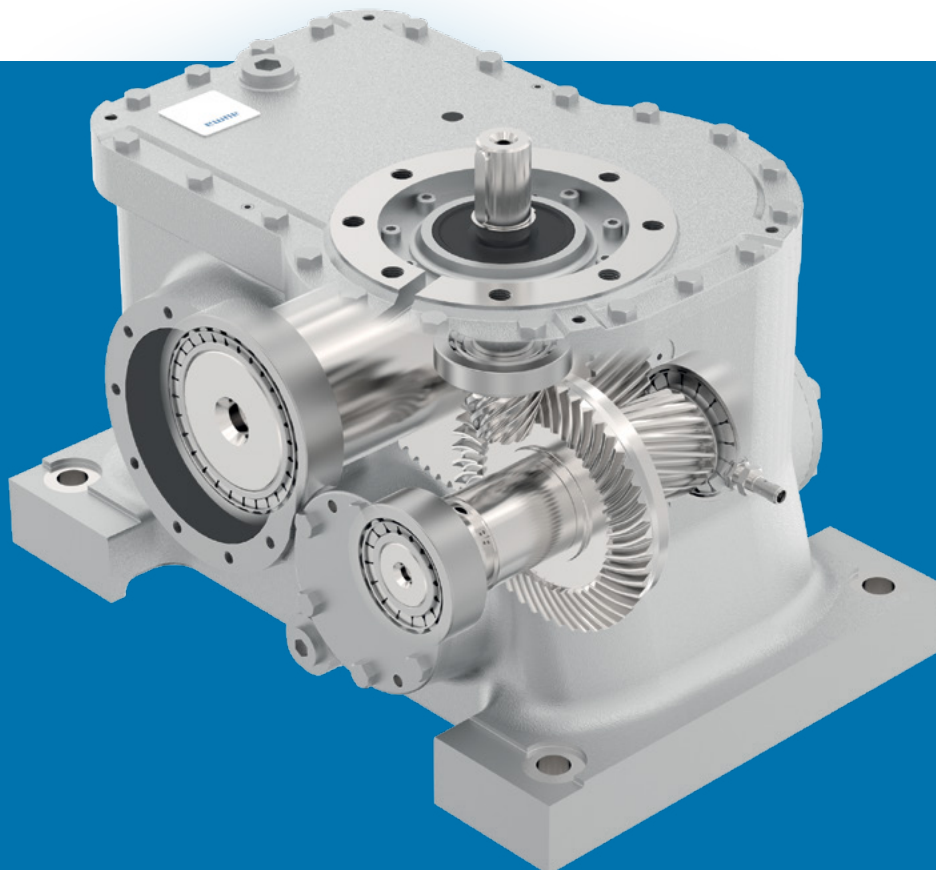

Noise emission, efficiency and lifetime

With regard to low-noise applications and noise emissions, worm gear units will always be the measure of all things. In our in-house acoustic measurement room complying with DIN standards, the acoustic pressure level of our escalator gear units is measured and recorded as part of final inspection.

Machining of worm wheel sets on state-of-the-art equipment as well as unique measuring technology, partially in special development projects in close cooperation with our partners, ensure optimum gear quality. When using synthetic polyglycol lubricants, typical heavy industry worm gearings achieve an efficiency rating of up to 97 % thanks to our gearing optimisation technology. Paired with the implementation of top grade

materials, selected standard parts and high precision housing machining, maximum service life and highest reliability are achieved. The evidence of these results were confirmed by internal verifications and tests on customers' test benches.

Options and mounting parts

If specifically desired, AUMA Drives escalator gear units can be provided with integrated sensor technology for monitoring oil level, oil sump temperature and system vibration. When implemented in extremely low temperature environments, we offer an optional oil heater to ensure optimum lubrication as early as during the start-up phase.

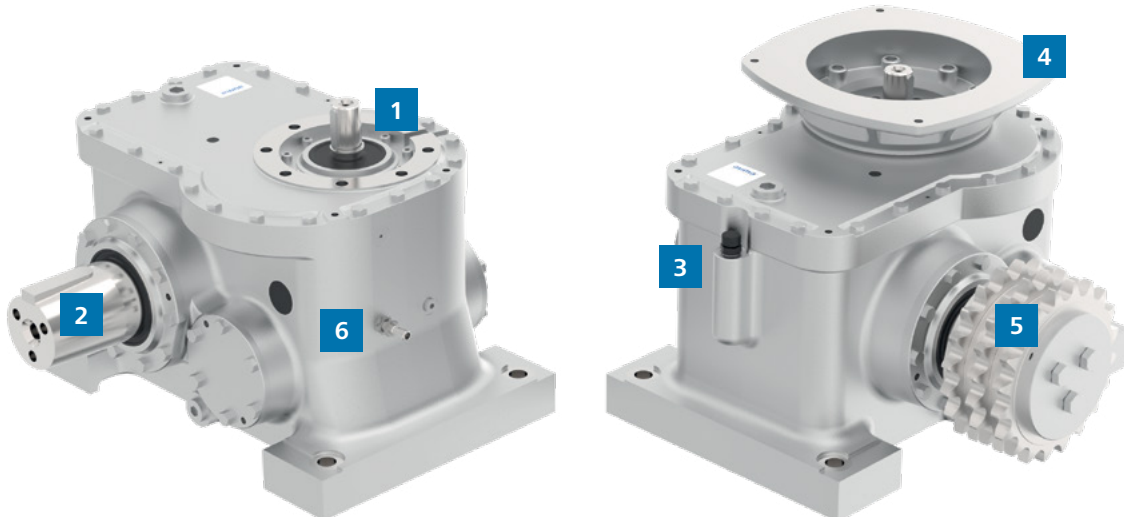

1 Input shaft

2 Output shaft

3 Air breather

4 Motor flange [option]

5 Chain pinion / sprocket [option]

6 Oil sensor (temperature and level) [option]

The peak of our gear units

AUMA Drives



Type FTHST 156.1

Performance

Transmission ratio 20.8

Lubrication	Polyglycol	
Ambient temperature	40 °C	
Efficiency	≥ 96 %	
Max. output torque	5.1 kNm (acc. to EN 115 » factor of safety ≥ 5)	$\alpha = 30 \dots 60^\circ$
Max. radial force	50 kN (acc. to EN 115 » factor of safety ≥ 5)	$x = 258 \text{ mm}$

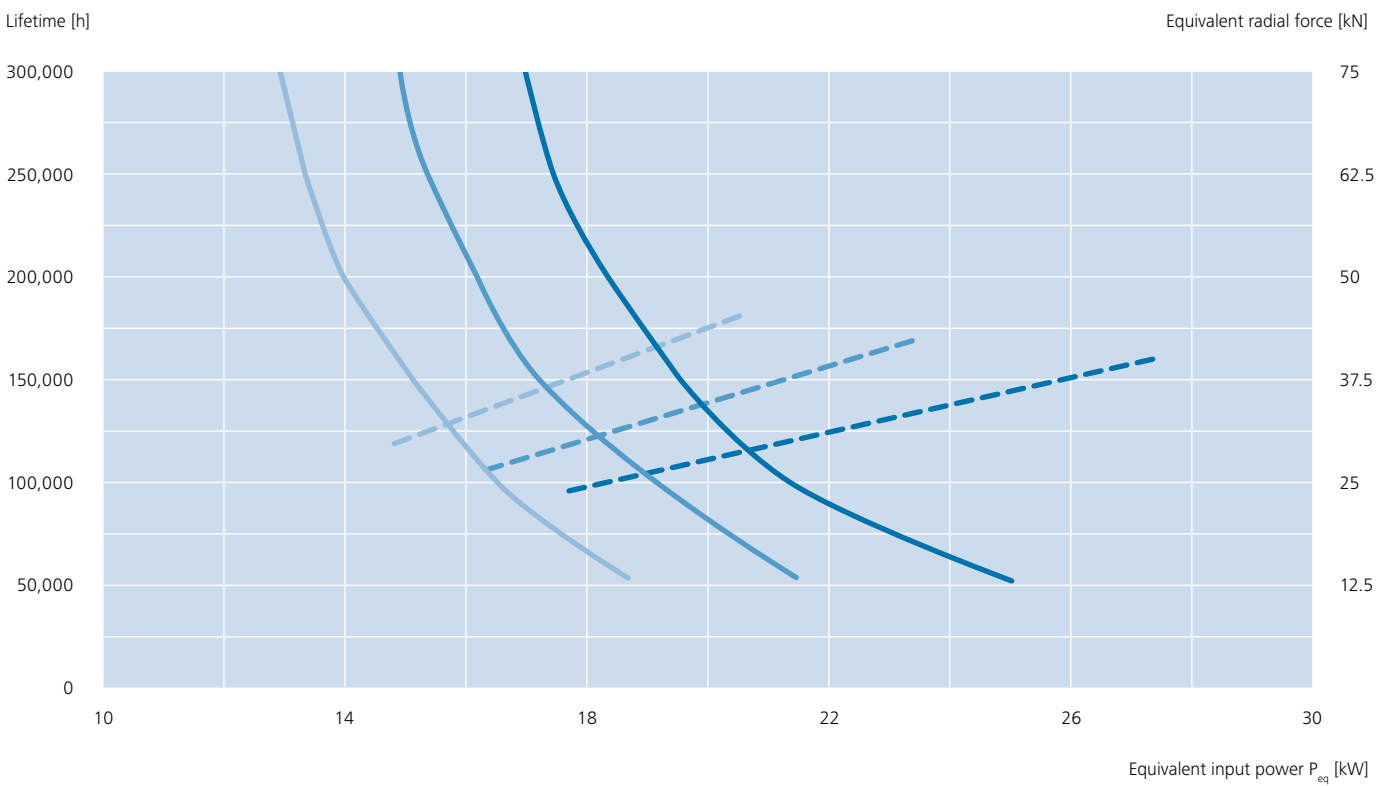
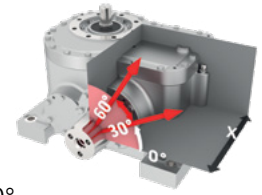

Lifetime	Radial force	Input speed [rpm]	Max. rated motor power [kW]	Max. rated radial force [kN]
—————	-----	980	17.0	32
—————	-----	1,180	18.6	30
—————	-----	1,480	18.6	29

The calculations of machine elements are based on the standards and guidelines, which reflect the current state of the art. Toothings comply with the latest revision of ISO 6336:2006 and ISO 10300:2014.

Performance
Type FTHST 156.1
Transmission ratio 25.9

Lubrication	Polyglycol	
Ambient temperature	40 °C	
Efficiency	≥ 96 %	
Max. output torque	4.8 kNm (acc. to EN 115 » factor of safety ≥ 5)	$\alpha = 30 \dots 60^\circ$
Max. radial force	47 kN (acc. to EN 115 » factor of safety ≥ 5)	$x = 258 \text{ mm}$

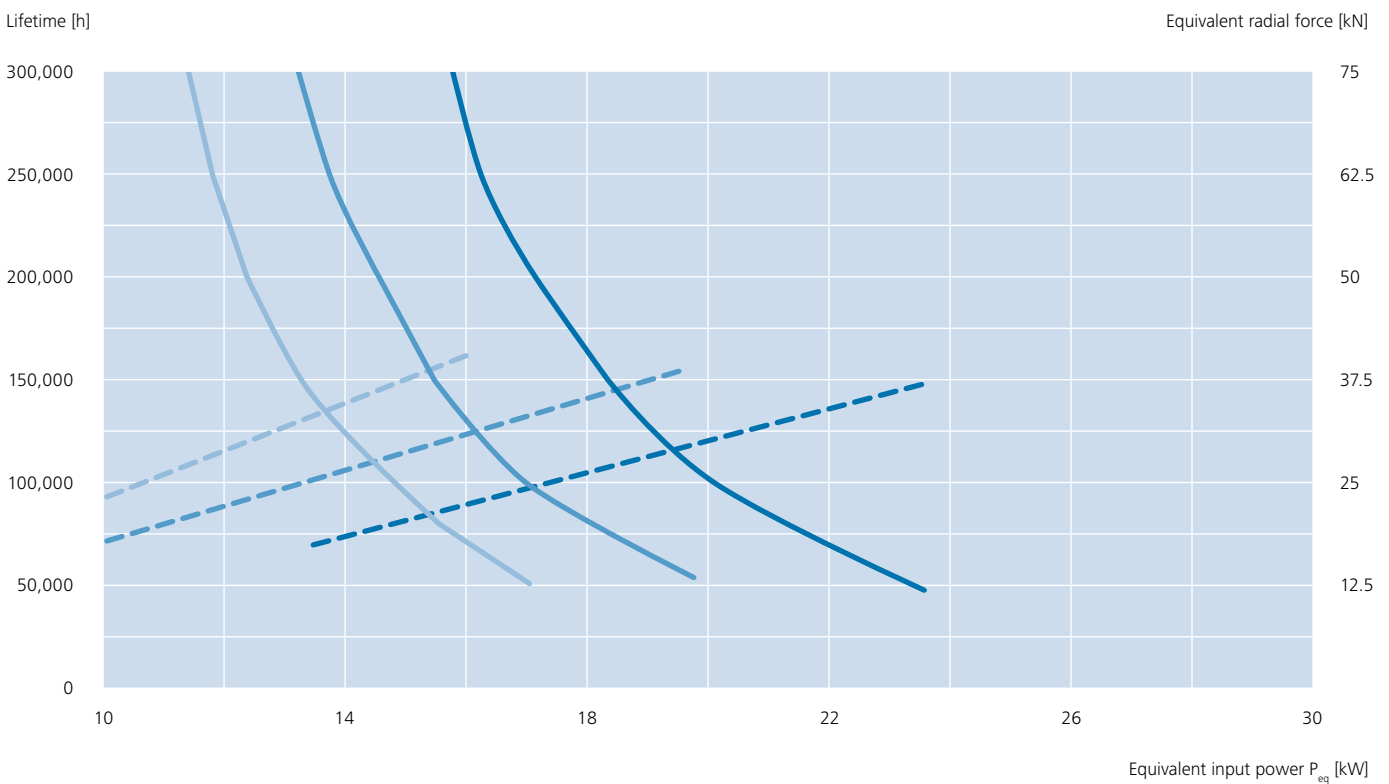
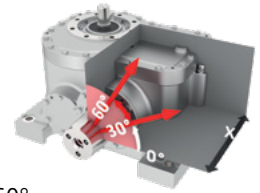

Lifetime	Radial force	Input speed [rpm]	Max. rated motor power [kW]	Max. rated radial force [kN]
—————	-----	980	13.5	32
—————	-----	1,180	15.5	29
—————	-----	1,480	18.6	24

The calculations of machine elements are based on the standards and guidelines, which reflect the current state of the art. Toothings comply with the latest revision of ISO 6336:2006 and ISO 10300:2014.

Combines 125 years of experience

AUMA Drives

Type FTHST 168.1

Performance

Transmission ratio 20.8

Lubrication	Polyglycol	
Ambient temperature	40 °C	
Efficiency	≥ 96 %	
Max. output torque	6.8 kNm (acc. to EN 115 » factor of safety ≥ 5)	$\alpha = 30 \dots 60^\circ$
Max. radial force	66 kN (acc. to EN 115 » factor of safety ≥ 5)	$x = 280 \text{ mm}$

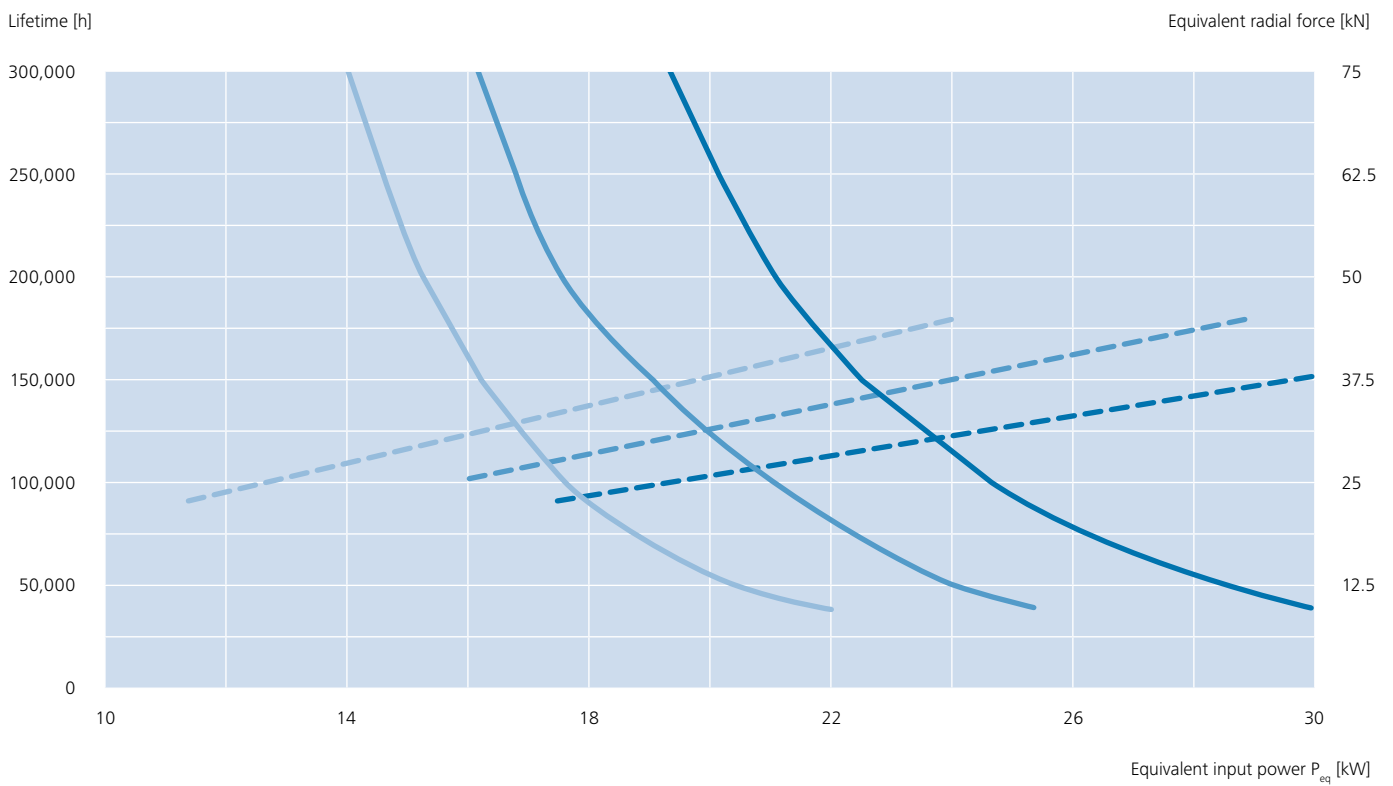
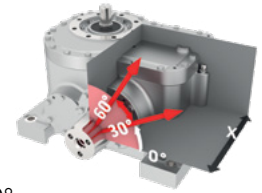

Lifetime	Radial force	Input speed [rpm]	Max. rated motor power [kW]	Max. rated radial force [kN]
—————	- - - - -	980	23.0	43
—————	- - - - -	1,180	24.0	38
—————	- - - - -	1,480	24.0	30

The calculations of machine elements are based on the standards and guidelines, which reflect the current state of the art. Toothings comply with the latest revision of ISO 6336:2006 and ISO 10300:2014.

Performance
Type FTHST 168.1
Transmission ratio 25.9

Lubrication	Polyglycol	
Ambient temperature	40 °C	
Efficiency	≥ 96 %	
Max. output torque	6.4 kNm (acc. to EN 115 » factor of safety ≥ 5)	$\alpha = 30 \dots 60^\circ$
Max. radial force	62 kN (acc. to EN 115 » factor of safety ≥ 5)	$x = 280 \text{ mm}$

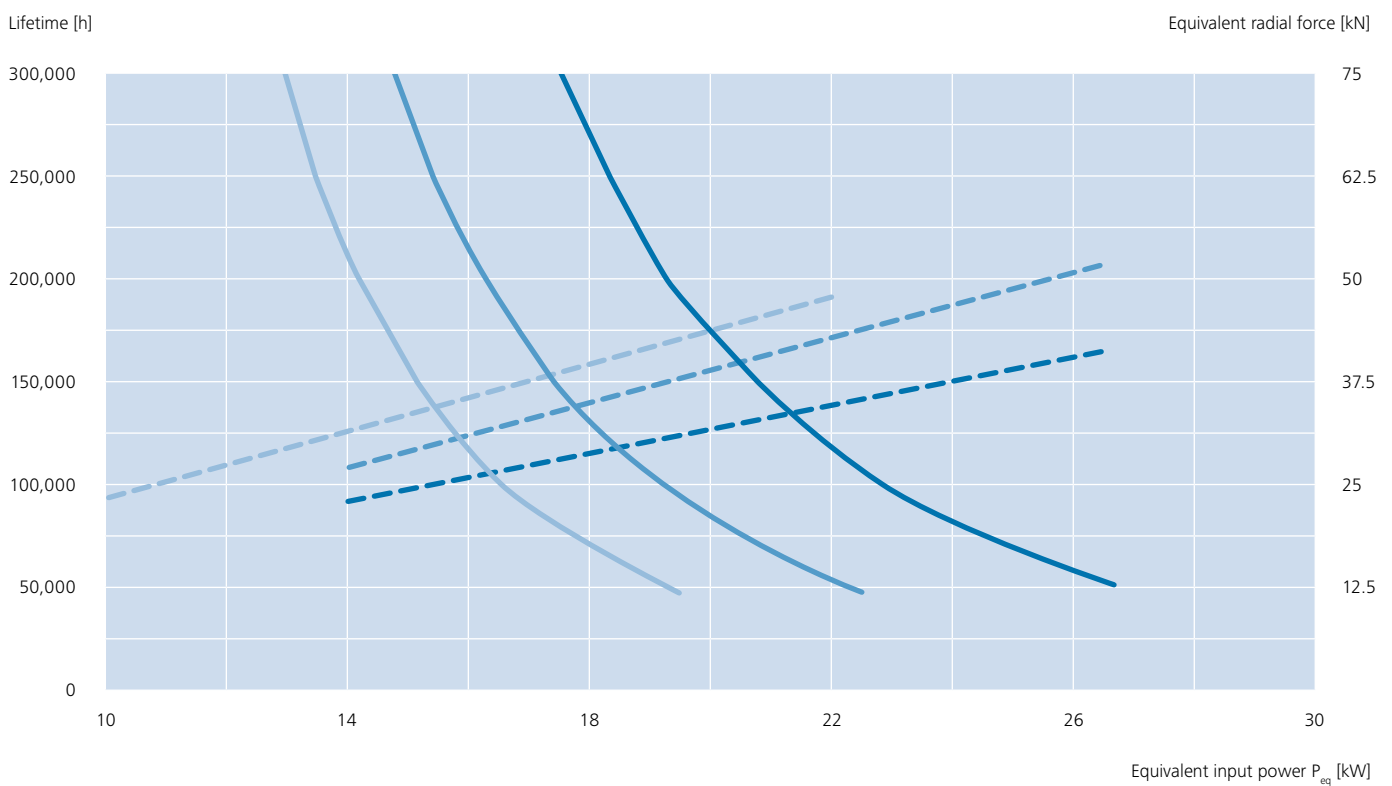
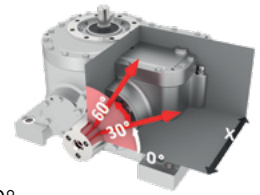

Lifetime	Radial force	Input speed [rpm]	Max. rated motor power [kW]	Max. rated radial force [kN]
—————	- - - - -	980	17.0	40
—————	- - - - -	1,180	20.5	40
—————	- - - - -	1,480	24.0	37

The calculations of machine elements are based on the standards and guidelines, which reflect the current state of the art. Toothings comply with the latest revision of ISO 6336:2006 and ISO 10300:2014.

For maximum efficiency

AUMA Drives



Type FTHST 182.1

Performance

Transmission ratio 20.8

Lubrication	Polyglycol	
Ambient temperature	40 °C	
Efficiency	≥ 96 %	
Max. output torque	8.4 kNm (acc. to EN 115 » factor of safety ≥ 5)	$\alpha = 30 \dots 60^\circ$
Max. radial force	70 kN (acc. to EN 115 » factor of safety ≥ 5)	$x = 300 \text{ mm}$

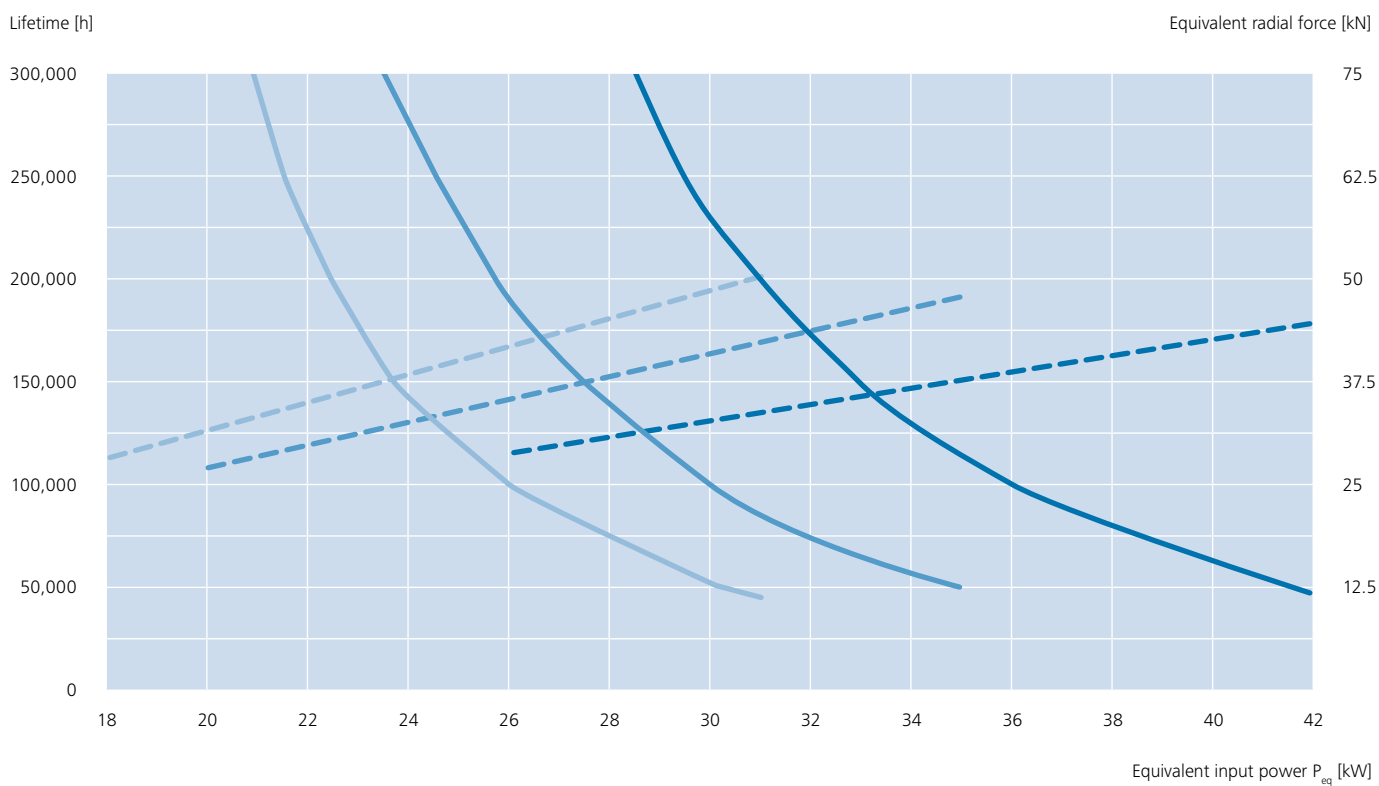
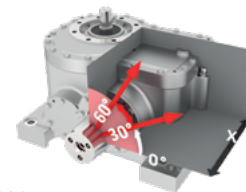

Lifetime	Radial force	Input speed [rpm]	Max. rated motor power [kW]	Max. rated radial force [kN]
—————	-----	980	27.5	45
—————	-----	1,180	33.0	45
—————	-----	1,480	33.0	36

The calculations of machine elements are based on the standards and guidelines, which reflect the current state of the art. Toothings comply with the latest revision of ISO 6336:2006 and ISO 10300:2014.

Performance

Type FTHST 182.1

Transmission ratio 25.9

Lubrication	Polyglycol	
Ambient temperature	40 °C	
Efficiency	≥ 96 %	
Max. output torque	7.8 kNm (acc. to EN 115 » factor of safety ≥ 5)	$\alpha = 30 \dots 60^\circ$
Max. radial force	65 kN (acc. to EN 115 » factor of safety ≥ 5)	$x = 300 \text{ mm}$

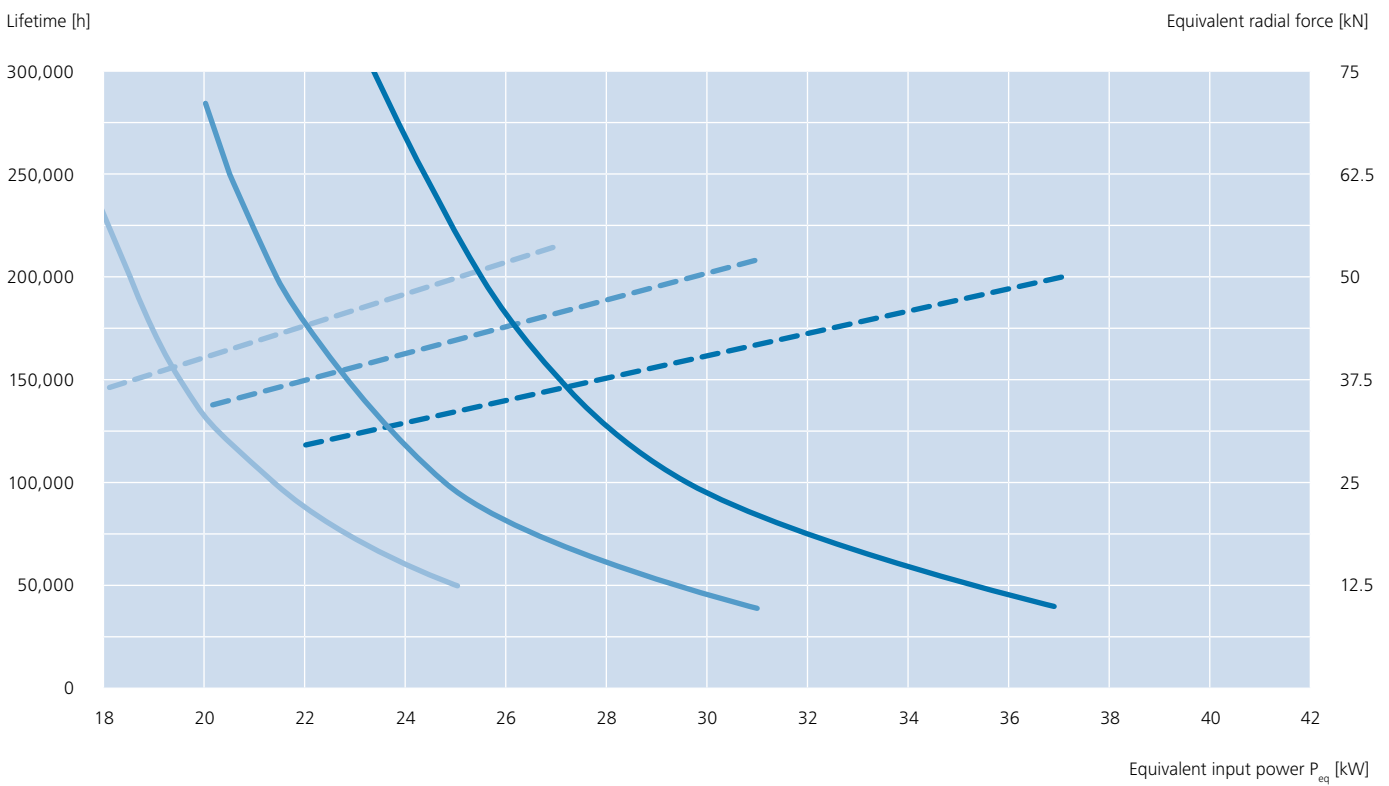
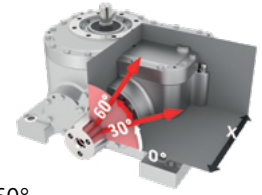

Lifetime	Radial force	Input speed [rpm]	Max. rated motor power [kW]	Max. rated radial force [kN]
—————	- - - - -	980	22.0	45
—————	- - - - -	1,180	26.5	45
—————	- - - - -	1,480	33.0	44

The calculations of machine elements are based on the standards and guidelines, which reflect the current state of the art. Toothings comply with the latest revision of ISO 6336:2006 and ISO 10300:2014.

Oil-Level and Temperature-Sensor_OTs

Condition monitoring of escalator drives is an elementary component for high system availability and the reduction of drive damage. The OTS sensor developed by AUMA Drives enables the combined monitoring of oil temperature and oil level in a single device.



Measurement principles	Oil level: capacitance based Temperature: Resistance
Measuring medium	Polyglycol oil
Level switch	Push-Pull / I _{max} = 100 mA
Switching behaviour	Oil level sufficient = high signal Oil level low = low signal
Temperature switch	Push-Pull / I _{max} = 100 mA
Switching behaviour	< Limit value = high signal > Limit value = low signal
Temperature limit value	Adjustable via interface Default value: +110 °C / +230 °F Hysteresis: 2 Kelvin
Medium temperature	-20...+120 °C / -4...+248 °F
Ambient temperature	-20...+50 °C / -4...+122 °F
Voltage	18...30 V DC
Operational pressure	Unpressurised
Contact material	Housing: Nickel-plated brass Sensor element: Epoxy resin, copper, solder resist Potting compound: epoxy resin
Connector	Circular connector M12x1 / 4-pin
Enclosure protection	IP67
Weight	approx. 0.05 kg
Conformity	CE
Wiring diagram	<p>1 brown → 18...30 V DC 2 white → signal output level 3 blue → 0 V 4 black → signal output temperature</p> <p>Connector M12x1</p>
Dimensions	

References

The list below is a small excerpt of public sector projects equipped with AUMA Drives escalator gear units.

Bart San Francisco 洛杉矶地铁	USA 美国
Canary Wharf - Crossrail 伦敦地铁	United Kingdom 英国
Marmaray, Istanbul 土耳其地铁	Turkey 土耳其
London Heathrow 伦敦希思罗机场	United Kingdom 英国
Highspeed Trainstation Tianjin to Beijing 北京天津高铁延长线	China 中国
Chengdu Metro 成都地铁2号线	China 中国
Lyon Confluence Phase 3 里昂地铁	France 法国
SNCF Montparnasse 法铁	France 法国
Rhätische Bahn Arosa 瑞士铁路	Switzerland 瑞士
SNCF Porte de Clichy 法铁	France 法国
SNCF Pereire-Levallois 法铁	France 法国
Métro Lille 法铁	France 法国
Shopping Mall, Hamburg 汉堡	Germany 德国
SNCF Gare de Lyon 法铁	France 法国
NZL Amsterdam Centraal Station 阿姆斯特丹中心地铁站	The Netherlands 荷兰
New Jersey Journal Square 新泽西地铁	USA 美国
Phoenix Sky Harbor International Airport 凤凰城机场	USA 美国
New York 7th-Avenue 纽约第7大街地铁站	USA 美国
Metro Cairo 开罗地铁	Egypt 埃及
Subway Madrid 马德里地铁	Spain 西班牙
Metro Napoli Toledo 意大利地铁	Italy 意大利
Subway Barcelona 巴塞罗那地铁	Spain 西班牙
Airport Dubai 迪拜机场	The United Arab Emirates 阿拉伯联合酋长国
Metro Moscow 莫斯科地铁	Russia 俄罗斯
WMATA Washington 华盛顿地铁	USA 美国
Taichung/Taipei 台中地铁	China Taipei 中国台北
Metro Tianjin 天津地铁6号线	China 中国
Subway Munich 慕尼黑地铁	Germany 德国
Metro Paris 巴黎地铁	France 法国
Metro Vienna 维也纳地铁	Austria 奥地利
Changsha Maglev 长沙磁悬浮	China 中国
Metro Salvador 萨尔瓦多地铁	Brazil 巴西
Metro Doha 多哈地铁	Katar 卡塔尔
Metro Chengdu Line 成都地铁 4号线	China 中国
Metro Wuhan 武汉地铁8号线	China 中国

AUMA: Part of something big

AUMA Drives GmbH is a specialist in high-precision drive technology, located in Coswig, Germany. The company focuses on developing and manufacturing robust gear units and complete drive solutions tailored for demanding industrial applications. With decades of experience and engineering excellence, AUMA Drives delivers customized solutions that meet the highest requirements for reliability, precision, and durability – particularly in sectors such as mechanical engineering, transport systems, and process automation.

As part of the AUMA Group, AUMA Drives benefits from a strong international network and shared expertise in electric actuators and automation solutions. The integration enables close cooperation within the group, especially in the area of modular drive systems. This synergy strengthens the group's ability to offer comprehensive, scalable drive technologies worldwide – from individual components to complex systems. AUMA Drives thus plays a crucial role in supporting the group's global positioning as a leading provider of smart drive solutions.

Did you know?

AUMA Drives Gear Units are also used in excavators, graders or combine harvesters. Visit our website and find out more.

www.auma-drives.com



Happy to take your questions

AUMA Drives GmbH

Grenzstr. 5, 01640 Coswig | Germany

+49 3523 94 60

info.drives@auma.com

www.auma-drives.com

2025 Issue