

Drives

Translation of Original operation instructions

Escalator gear units

FTSST158.1, FTSST180.1, FTSST212.1, FTSST260.1

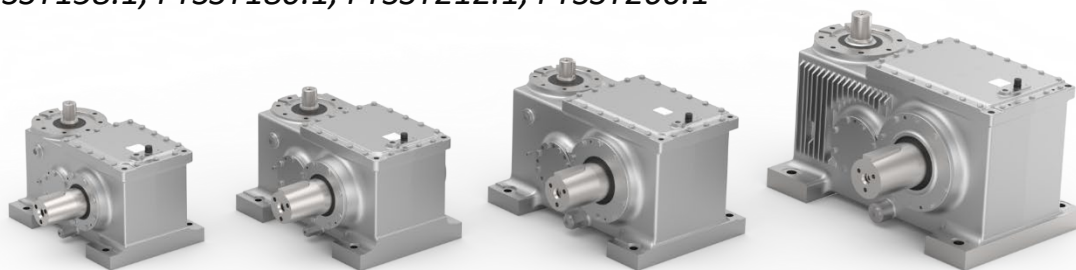

AUMA Drives GmbH
Grenzstraße 5
01640 Coswig/Germany
Phone: +49 (0) 3523 94 60
www.auma-drives.com

AUMA Drives Service
Phone: +49 (0) 3523 94 60
Service.drv@auma.com

Table of contents

| | |
|--|-----------|
| 1. Introduction | 3 |
| 2. Safety instructions | 3 |
| 2.1. Intended use | 3 |
| 2.2. Inappropriate or unintended use | 4 |
| 2.3. Warnings and notes, symbols and their signification | 4 |
| 2.4. Important instructions, basic duties, warranty and liability | 4 |
| 3. Technical description | 5 |
| 3.1. Design | 6 |
| 3.2. Name plate | 7 |
| 3.3. Technical data | 7 |
| 3.3.1. Dimensions | 7 |
| 3.3.2. Gear unit weight | 7 |
| 3.3.3. Lubricant | 7 |
| 3.3.4. Sound pressure level | 8 |
| 4. Delivery, transport, handling & storage | 9 |
| 5. Assembly | 10 |
| 5.1. Gear unit assembly | 10 |
| 5.2. Mounting the brake motor | 11 |
| 5.3. Mounting the pinion | 11 |
| 5.3.1. Permissible effective direction of chain load | 12 |
| 6. Commissioning | 12 |
| 7. Operation, malfunctions, causes, troubleshooting | 13 |
| 8. Maintenance and repair | 14 |
| 8.1. Description of maintenance work | 14 |
| 8.1.1. Oil level and status monitoring | 14 |
| 8.1.2. Oil change | 15 |
| 8.1.3. Cleaning the breather | 16 |
| 8.2. Spare parts | 17 |
| 9. Disposal | 18 |
| 10. Appendix I: Dimension sheet FTSST158.1 | 19 |
| 11. Appendix II: Dimension sheet FTSST180.1 | 20 |
| 12. Appendix III: Dimension sheet FTSST212.1 | 21 |
| 13. Appendix IV: Dimension sheet FTSST260.1 | 22 |
| 14. Appendix V: Declaration of Incorporation | 23 |

1. Introduction

The present operation instructions are part of the scope of supply and should be stored, if possible, near the gear unit where they can easily be accessed. Installation, commissioning and maintenance work may only be performed by qualified personnel who have both read and understood these operation instructions. AUMA Drives shall not be held liable for any damage or failure incurred by non-observance of these instructions.

Escalator gear units have been designed in accordance with recognised standards, directives and safety regulations and correspond to the technical status at the time of printing of these operation instructions. We reserve the right to perform technical alterations on the products.

The copyright of these operation instructions remains with AUMA Drives GmbH, hereinafter called "AUMA Drives". The operation instructions shall neither be used completely nor in parts without authorisation nor be made available to third parties without our prior consent.

For further information, please contact the AUMA Drives service department:

AUMA Drives Service

Phone: +49 (0) 3523 94 60

service.driv@auma.com

2. Safety instructions

2.1. Intended use

Escalator gear units are exclusively designed for use in escalator gear units for conveying passengers in accordance with EN 115:2017. Other applications require explicit (written) approval by the manufacturer.

Escalator gear units have been designed and developed in accordance with recognised standards, directives and safety regulations and are supplied ready to operate. Machinery Directive 2006/42/EC applies to escalator units. They are partly completed machinery to be installed in an escalator. The required Declaration of Incorporation of Partly Completed Machinery is included in section 13 of these operation instructions. The machine operator or the machine manufacturer must ensure that all legal requirements, directives, guidelines, national regulations and recommendations with respect to assembly, commissioning and operation are met at the place of installation.

Installation, commissioning and maintenance work must be exclusively performed by qualified personnel. Qualified personnel are persons, who, because of their training, experience and position as well as their knowledge of appropriate standards, regulations, health and safety requirements and working conditions, are authorised by the person responsible for the safety of the equipment to perform the required duties and are therefore aware of, and can report, possible hazards. (Definition of qualified employees according to IEC 60364)

Intended use includes observance of the operation instructions or observance of the instructions and specifications included. Furthermore, fulfilment of the legal provisions on occupational health and safety and the prevention of accidents, as well as heeding of safety instructions and warning signs attached to the product to avoid both personal injuries and property damage must be ensured.

Operation instructions

Escalator gear units

FTSST158.1 / FTSST180.1 / FTSST212.1 / FTSST 260.1

2.2. Inappropriate or unintended use

Any uses other than those indicated in section 2.1 are either inappropriate or unintended. AUMA Drives shall not assume any liability for personal injuries or property damage incurred from this use.

Inappropriate or unintended use includes among others:

- Upgrading as elevator gear unit
- Use in potentially explosive atmosphere
- Use outside technically and contractually agreed limits (output speeds, power, torques, ambient conditions)

Improper use furthermore includes:

- Operation without oil filling or with an inappropriate lubricant as well as operation without breather.
- Opening the gear unit when installed. During the warranty period, gear units may only be opened with prior consent of the manufacturer, otherwise any warranty claim will be void.
- Any modifications on the gear unit and in particular those impairing operational safety and reliability

2.3. Warnings and notes, symbols and their signification





| Symbol | Signification |
|---|---|
|   | Indicates safety instructions which have to be observed to avoid personal injuries (injuries, death). |
|  | Indicates safety instructions which have to be observed to avoid damage at the gear unit. |
|  | General instructions, hints. |

Table 2.3: Warnings and symbols

2.4. Important instructions, basic duties, warranty and liability

- The escalator manufacturer/operator have to ensure that the all specifications and instructions have been read, understood and heeded to:
 - Avert threats to life or physical condition
 - Ensure operational safety of the gear unit and
 - Avoid both installation downtimes and damage to the environment
- The manufacturer of the complete equipment is obliged to include these operation instructions in the operation instructions of the equipment.
- The escalator manufacturer/operation shall be held liable for expert installation (assembly), maintenance and operation of the escalator gear unit. This work may only be performed by qualified and trained personnel.
- Work always has to be performed while the gear unit is switched off and protected against accidental start-up (key switch, sign).
- In case of detected defects as well as for malfunctions such as increased noise levels, oil leakage, rising operating temperature, etc., the gear unit must be shut down immediately. All defects must be remedied before restarting the equipment.
- During the warranty period, the gear units may only be opened with AUMA Drives' prior consent.

Operation instructions

Escalator gear units

FTSST158.1 / FTSST180.1 / FTSST212.1 / FTSST 260.1

- Prior to using the gear unit, the data on the name plate has to be compared with the data of the collateral documents (delivery note, order acknowledgement, test report, etc.) for compliance.
- Welding at the gear unit is not permitted and the gear unit must not be used for protective earth connection.
- Revolving and rotating parts must be protected against accidental contact.
- The escalator manufacturer or escalator operator are responsible for implementing required protective measures on site, such as enclosures, barriers, or personal protective equipment for the staff.
- Under certain operation conditions, the surface temperature of the gear unit may rise up to 110°C. Danger of burns!
- Danger of burns due to hot oil when changing oil.
- Cleaning with a high pressure cleaner is not permitted.
- Spare parts must generally be ordered with AUMA Drives.

Failure to observe the specifications indicated entails complete exclusion of liability and warranty expires. Consequential damage of inappropriate use can include property damage and personal injuries and even death.

3. Technical description

Escalator gear units of the FTSST type range are worm helical gear units. They combine the advantages of worm gear units and helical gears and are characterised by extremely low noise, high efficiency, utmost reliability and long service life.

Gear units of type FTSST are prepared for installation of customer-specific flanges for direct installation of the brake motor. The motor is mounted using a coupling.

Depending on the escalator configuration, types FTSST provide the option of mounting the drive shaft or the pinion on side A or side B – for more information, refer to the dimension sheets in the appendix (sections 10 to 12).

CAUTION!

Escalator gear units may only be used in the service position shown in the illustration!

→ Vertical drive shaft, motor above the gear unit!

CAUTION!

Escalator gear units are not self-locking.

Section 3.1 provides a schematic description of the escalator gear unit design. Major sub-assemblies are designated.

Operation instructions

Escalator gear units

FTSST158.1 / FTSST180.1 / FTSST212.1 / FTSST 260.1

3.1. Design

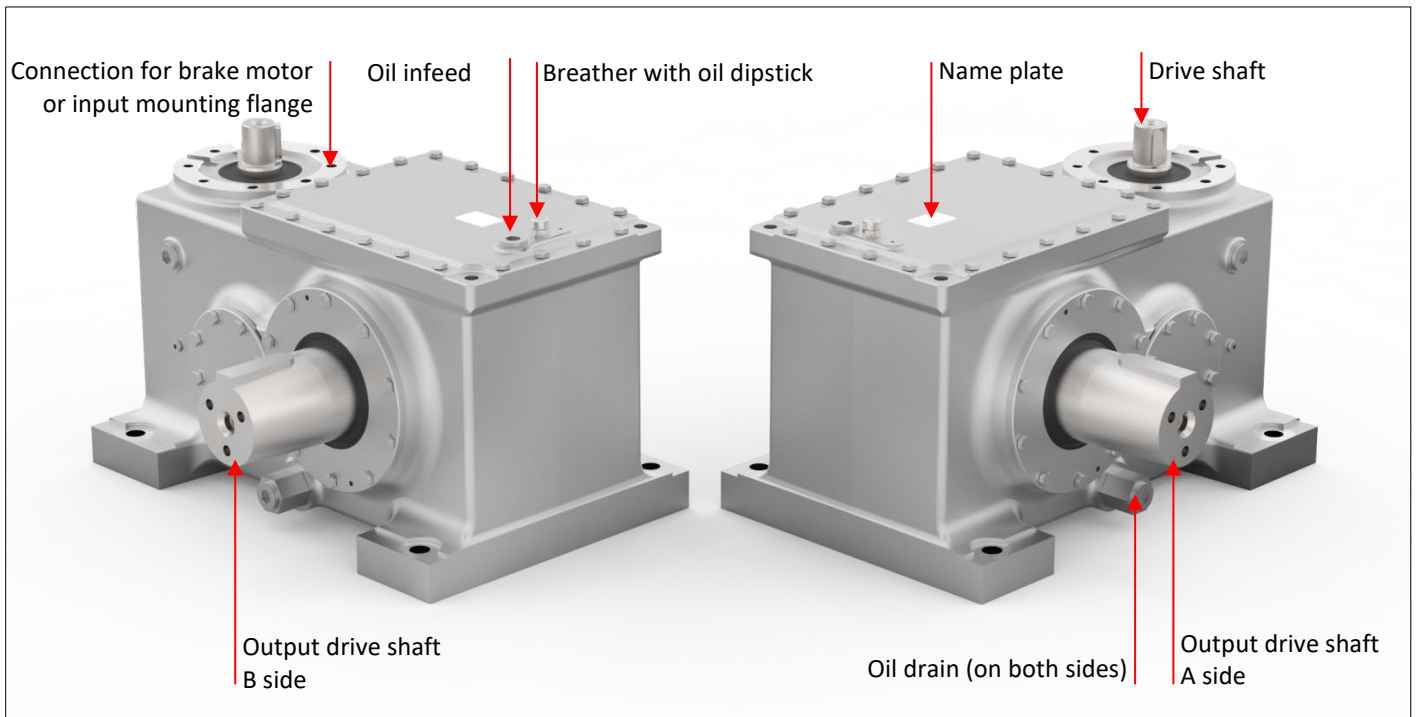

Figure 3.1-1: Design of basic version, FTSST212.1 as an example



In addition to the standard versions, installation-specific equipment is available as an option. This includes flanges, pinion, oil heater and monitoring equipment such as acceleration or vibration sensors as well as oil temperature sensors.

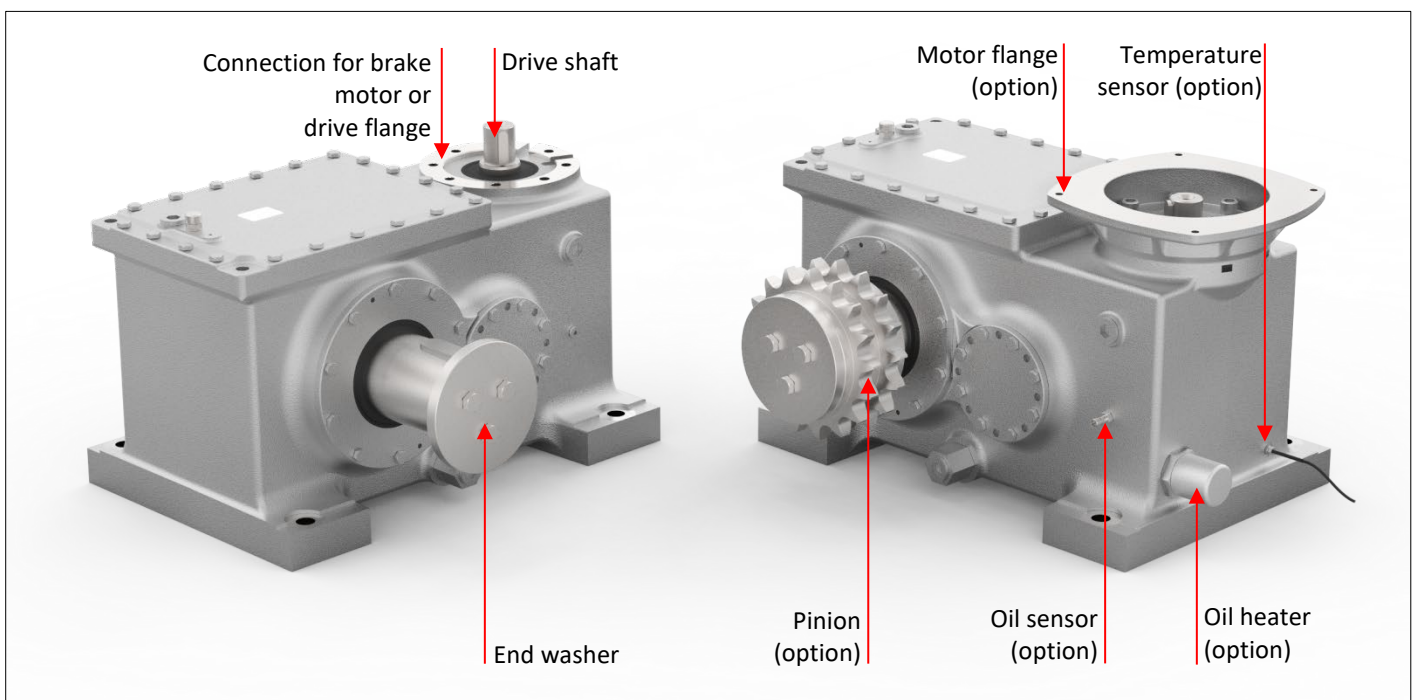

Figure 3.1-2: Mounting options (FTSST212.1 as an example)

Operation instructions

Escalator gear units

FTSST158.1 / FTSST180.1 / FTSST212.1 / FTSST 260.1

3.2. Name plate

The following data is provided on the name plate attached to the gear unit.

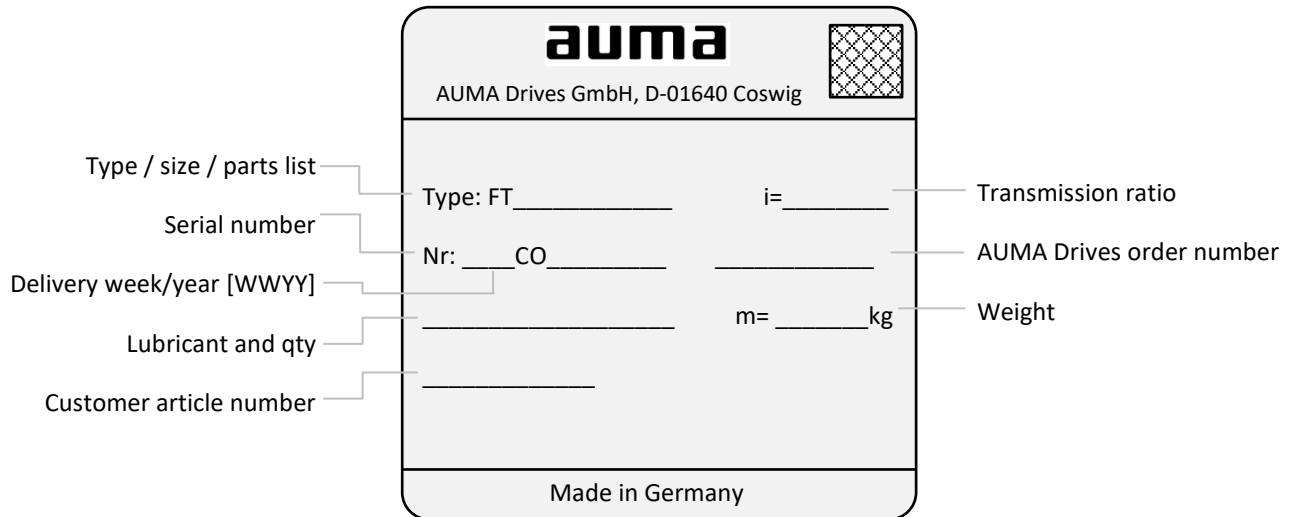

3.3. Technical data

3.3.1. Dimensions

For the dimension sheets, refer to the appendix (sections 10 to 12) of these operation instructions.

3.3.2. Gear unit weight

| Size | Gear unit weight ca. [kg] ¹⁾ |
|------------|---|
| FTSST158.1 | 167 |
| FTSST180.1 | 257 |
| FTSST212.1 | 351 |
| FTSST260.1 | 622 |

Table 3.3.2: Gearbox weight

¹⁾ incl. oil

3.3.3. Lubricant

Escalator gear units are lubricated by splash lubrication, i.e. the roller bearings are automatically supplied with oil. Unless agreed otherwise, the gear units are supplied with oil filling when leaving the factory.

We exclusively use CLP-PG oils (according to DIN 51517-part 3). These fully synthetic oils (polyglycoles) have outstanding temperature-viscosity behaviour and excellent characteristics with regard to corrosion protection, resistance to ageing and wear reduction. For ambient temperatures between -10 °C and $+40\text{ °C}$, oils of ISO viscosity class VG460 must be used. For other ambient conditions, a suitable lubricant has to be selected by AUMA Drives.

The table below lists lubricants by different manufacturers. The lubricant used is indicated on the name plate.

Operation instructions

Escalator gear units

FTSST158.1 / FTSST180.1 / FTSST212.1 / FTSST 260.1

| Marking according to DIN 51517-3 and DIN 51519 | Klüber | ARAL | Shell | Mobil | Bechem | Castrol |
|---|--------------------------------------|-----------------|----------------|-----------------|----------------------|-------------------|
| CLP PG ISO VG 460 | Klübersynth GH 6-460 ¹ | Degol GS 460 | Tivela S460 | Glygoyle 460 | Berusrynth EP 460 | Optiflex A 460 |

Table 3.3.3-1: Lubricants

¹⁾ Factory standard

CAUTION!

AUMA Drives shall not assume any warranty for the perfect suitability of all listed lubricants.



Mixing oils of various types and manufacturers is not permissible. Mineral oils in particular must not be used. Refer to the name plate for the lubricant used.

CAUTION!

The table below shows the required oil quantities. These values are reference values. The filling level (of the cooled down oil) within the gear unit, defined by markings (max. and min.) on the oil dipstick is relevant - refer to figure 3.3.3.

| Size | Oil volume ca. [l] |
|------------|--------------------|
| FTSST158.1 | 10.0 |
| FTSST180.1 | 16.0 |
| FTSST212.1 | 21.0 |
| FTSST260.1 | 40.0 |

Table 3.3.3-2: Lubricant quantity



Figure 3.3.3: Breather with oil dipstick

3.3.4. Sound pressure level

Within the framework of the final inspection, escalator gear units are subjected to noise measurement based on the engineer method in accordance with DIN 45635-1 and -23 at a test load of 3 kW.

| Size | Sound pressure level L_{pA} [dB(A)] ² |
|------------|--|
| FTSST158.1 | 58 |
| FTSST180.1 | 60 |
| FTSST212.1 | 62 |
| FTSST260.1 | 63 |

Table 3.3.4: Sound pressure level

²⁾ at a distance of 1 m to housing surface

Operation instructions

Escalator gear units

FTSST158.1 / FTSST180.1 / FTSST212.1 / FTSST 260.1

4. Delivery, transport, handling & storage

Prior to delivery, all escalator gear units are subjected to final inspection and leave AUMA Drives in perfect condition and suitably packaged according to their destination. Upon receipt, the delivery has to be inspected for completeness and possible transport damage. Notify the forwarding company or the customer service of AUMA Drives of any possible defects. Commissioning the gear unit might not be permitted.



Gear units must be stored and transported in service position at all times (refer to note in section 3 and dimension sheet in the appendix). The breather is enclosed with the delivery and must be mounted prior to commissioning (also refer to section 6 "Commissioning")!



Only use lifting appliances and load suspension equipment with sufficient bearing capacity for transport! For the overall weight of the gear unit, refer to the name plate. Reference values can also be found in section 3.3.2. **The load is borne by respectively three suitable eye bolts. Ensure that they have been firmly screwed to the housing.** The threads illustrated in figure 4 may be exclusively used for transport.

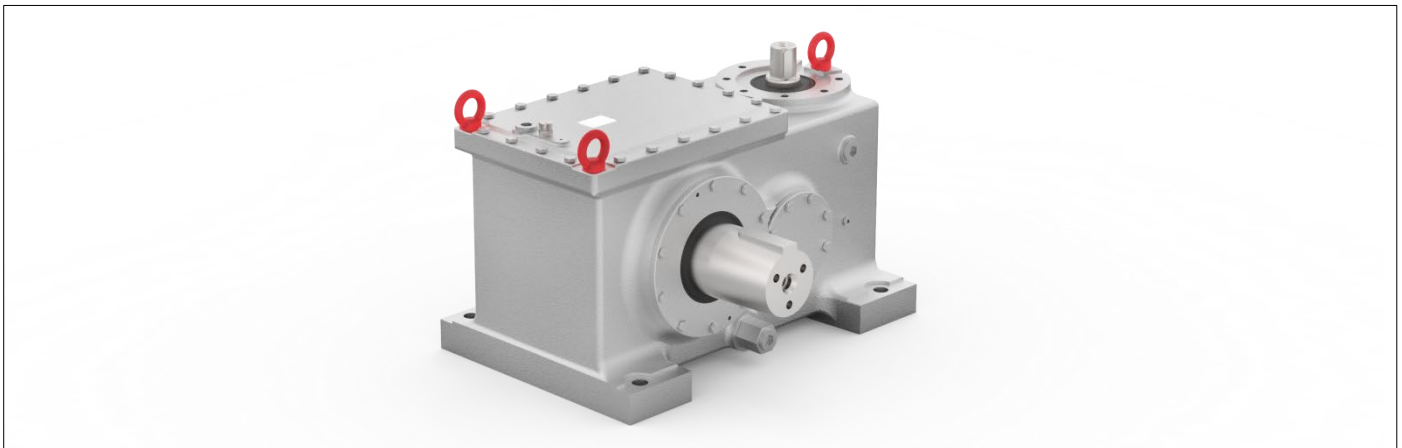

Figure 4: Lashing points

| Size | Transport eye bolts |
|------------|---------------------|
| FTSST158.1 | 3x M16 |
| FTSST180.1 | 3x M16 |
| FTSST212.1 | 3x M16 |
| FTSST260.1 | 3x M20 |

Table 4: Transport eye bolts

CAUTION!

Handle and transport with care to prevent damage. **Hits and blows to the shaft ends might cause damage within the gear unit.**

The gear units may only be stored in closed rooms at even temperature. Avoid exposure to direct sunlight. Relative humidity must not exceed 70 %.



Gear units must be stored on levelled base plates, protected against vibration, and must not be stacked on top of each other.

Operation instructions

Escalator gear units

FTSST158.1 / FTSST180.1 / FTSST212.1 / FTSST 260.1

Unless agreed otherwise, escalator gear units are supplied with oil filling in the factory (long-term lubrication, inner parts are provided with protection for 36 months). If initial oil filling is not provided by AUMA Drives, the inner parts are protected with a short-term corrosion protection, sufficient for 6-month storage/transport.



Free shaft ends and metallic, uncoated (flange) surfaces are also provided with 6-month protection. For longer storage periods, we recommend verifying the inner and outer status of the gear unit and applying a new corrosion protection layer if required. Storage periods start with receipt of delivery.

CAUTION!

The corrosion protection can be removed using common cleaning agents. The cleaning agent must not come into contact with radial seals.



Ensure sufficient ventilation while removing the corrosion protection agent. Due to potentially explosive atmospheres, open fire is not permitted.

The outer coating (top coat based on polyurethane) is resistant to weak chemicals such as oils, resistant to mechanical impacts and temperature resistant up to 150 °C. Damage to the coating of the outer parts leads to failure of the corrosion protection and has to be touched up immediately. Sand blasting of the gear unit is not permitted.

5. Assembly

5.1. Gear unit assembly



The safety instructions in section 2 must be observed.

The following conditions must be met for installing the escalator gear unit:

- These operation instructions were completely read and understood by the assembly personnel.
- Suitable lifting devices are available in sufficient quantity.
- The data on the name plate and the application must correspond to the contractually agreed values (reduction ratio, output speed, etc.).
- The gear unit must not be damaged.
- Unless agreed otherwise, the ambient temperature must be between –10 °C and +40 °C.
- The environment of the installation site must be free of chemicals, acids, gases, etc.
- The gear unit must not be exposed to heat accumulation and waste heat from other devices.
- Mount the breather at the provided position (refer to section 6 "Commissioning").
- Breather including oil dipstick and oil draining screw plug must be freely accessible for maintenance work when installed.
- The corrosion protection agent must be removed from shaft ends and mounting faces (flanges).
- Machine frame:
The base must be designed for the weights and torques so that no additional loads resulting from distortion or twisting can act on the gear unit. Ensure that all mounting faces are flush on the machine frame. Non-observance might cause damage on and within the gear unit.

CAUTION!

Escalator gear units of type FTSST may only be mounted in the intended service position (vertical drive shaft, motor above the gear unit). **Use screws and nuts to fasten gear units via all through bores within the gear unit base to the machine frame.** We recommend applying the property classes and tightening torques indicated in table 5.1.

Operation instructions

Escalator gear units

FTSST158.1 / FTSST180.1 / FTSST212.1 / FTSST 260.1

| Size | Number and thread size of fastening screws | Required property class | Tightening torque [Nm] |
|------------|--|-------------------------|------------------------|
| FTSST158.1 | 4x M20 | 10.9 | 615 |
| FTSST180.1 | 4x M20 | 10.9 | 615 |
| FTSST212.1 | 4x M24 | 10.9 | 1050 |
| FTSST260.1 | 4x M30 | 10.9 | 2120 |

Table 5.1: Gear unit: Fastening screws and tightening torques

Welding at the gear unit is not permitted and the gear unit must not be used for protective earth connection!

5.2. Mounting the brake motor

The motor is mounted using flange and coupling. The following property classes and tightening torques have to be applied for fastening:

| Size | Number and thread size of fastening screws | Required property class | Tightening torque [Nm] |
|------------|--|-------------------------|------------------------|
| FTSST158.1 | 8x M16 | 8.8 (10.9) | 210 (310) |
| FTSST180.1 | 8x M16 | 8.8 (10.9) | 210 (310) |
| FTSST212.1 | 8x M16 | 8.8 (10.9) | 210 (310) |
| FTSST260.1 | 8x M20 | 8.8 (10.9) | 430 (615) |

Table 5.2: Motor: Fastening screws and tightening torques

CAUTION!

Do not apply hammer blows for assembly. This might damage the splines, roller bearings and the shafts. Heed operation instructions of the motor manufacturer for electrical connection!

5.3. Mounting the pinion

After removing the corrosion protection agent and cleaning the output shaft, a suitable anti-seizing compound (e.g. Gleitmo 800 by Fuchs) is applied to both the shaft and the hub of the pinion. The pinion is then pressed on the shaft up to the end stop (shoulder on the output shaft), using the fixture (refer to fig. 5.3). As an alternative, the pinion shaft can be mounted while hot ($\leq 120^{\circ}\text{C}$; wear heat resistant gloves!). Finally, the washer is mounted. For the tightening torque of the screws, refer to table 5.3. Secure screw using thread locking adhesive (e.g. Loctite 2701).

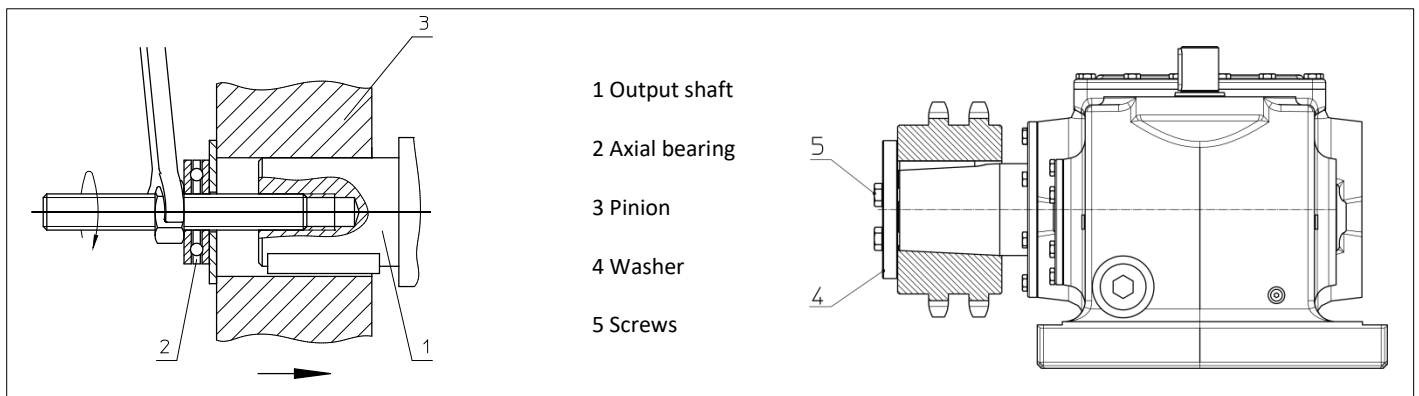

Figure 5.3: Pinion assembly

Operation instructions

Escalator gear units

FTSST158.1 / FTSST180.1 / FTSST212.1 / FTSST 260.1

| Size | Width across flats s of screws [mm] | Number and thread size of the screws | Required property class | Tightening torque [Nm] |
|------------|-------------------------------------|--------------------------------------|-------------------------|------------------------|
| FTSST158.1 | 24 | 3x M16 | 8.8 (10.9) | 190 (295) |
| FTSST180.1 | 24 | 3x M16 | 8.8 (10.9) | 190 (295) |
| FTSST212.1 | 24 | 3x M16 | 8.8 (10.9) | 190 (295) |
| FTSST260.1 | 24 | 3x M16 | 8.8 (10.9) | 190 (295) |

Table 5.3: Screws and tightening torques of pinion

5.3.1. Permissible effective direction of chain load

CAUTION!

Radial forces F_R resulting from the chain load must not exceed the limit values indicated in table 5.3.1 with regard to the effective direction. Deviating values can result in damage to bearing and shaft. Thrusts acting upon the output drive shaft are not permissible.

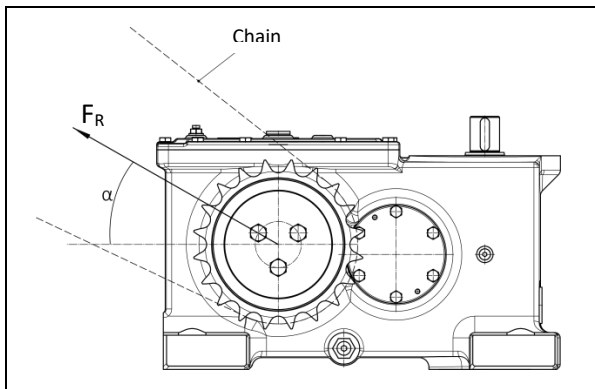

Figure 5.3.1: Radial forces and effective direction

| Size | Permissible Effective direction α [°] |
|------------|--|
| FTSST158.1 | 0 ... 60 |
| FTSST180.1 | 0 ... 60 |
| FTSST212.1 | 0 ... 60 |
| FTSST260.1 | 0 ... 60 |

Table 5.3.1: Radial forces and effective direction

6. Commissioning



The safety instructions in section 2 must be observed.



Commissioning of the gear unit is only permitted once the escalator manufacturer/operator have integrated the gear unit in the escalator, when complying with product specific European directives by affixing the CE mark on the escalator and after confirming the safety of the system put on the market.

CAUTION!

Prior to commissioning, the following steps have to be performed:

- Mount the breather at the provided position (refer to section 3 and dimension sheets in appendix). For this, remove the transport screw plug and fasten the breather according to tightening torque specified in table 8.1.1.
- Check oil filling level → section 8.1.1
- Check oil quality → section 8.1.1
- Check screw tightening torques:
 - Mounting of motor → section 5.2
 - Mounting of pinion → section 5.3
 - Mounting gear unit to base → section 4

Screws which must not be reused due to damage and wear have to be replaced by new ones of the same property class and type.

Operation instructions

Escalator gear units

FTSST158.1 / FTSST180.1 / FTSST212.1 / FTSST 260.1



Escalator gear units achieve their full performance in well run-in condition and at service temperature. We recommend running in each gear unit with no load for some time first and then at approx. 50% of the rated load for several hours. If operation at partial load is not possible, the gear should be repeatedly stopped once an oil temperature of approx. 80 – 90°C is reached. During running in, check for unusual noise and vibration, formation of smoke or vapour as well as the service temperature (gear unit surface up to approx. 70 °C). After running in, check gear unit for leakage.

7. Operation, malfunctions, causes, troubleshooting

Gear units must be monitored during operation. Special attention should be paid to unusual running noise, increased service temperatures and possible oil leakage.

CAUTION!

In case of irregularities and when eliminating malfunctions, the gear unit must be shut down immediately and the safety instructions of section 2.4 have to be observed. The equipment has to be protected against accidental start-up.



During the warranty period, maintenance work may exclusively be carried out by AUMA Drives. If malfunctions occurring at a later date cannot be located or the effort required for repair would be excessive, please contact the AUMA service technicians.

CAUTION!

Escalator gear units of the FTSST type range are not self-locking. When bleeding all brakes installed within the drive system, the escalator may automatically start depending on the load.

| Fault | Possible causes | Remedy |
|--------------------------------------|---|---|
| Unusual running noise/vibration | <ul style="list-style-type: none">• Damage to splines or bearing• Changed bearing backlash• Oil level too low | <ul style="list-style-type: none">• Contact AUMA Drives Service• Contact AUMA Drives Service• Refill oil and check gear unit for leakage |
| Unusual blows/vibration | <ul style="list-style-type: none">• Defective motor coupling• Gear support worked loose | <ul style="list-style-type: none">• Replace coupling• Tighten fastening screws according to section 5.1 |
| Increased service temperature | <ul style="list-style-type: none">• Heat accumulation and /or waste heat from other devices• Oil level too low• Outdated/contaminated oil | <ul style="list-style-type: none">• Contact AUMA Drives Service• Check oil level at room temperature and correct in accordance with section 3.3.3, if applicable• Change oil |
| Oil leaks at gear unit | <ul style="list-style-type: none">• Damaged radial seals• Clogged breather | <ul style="list-style-type: none">• Contact AUMA Drives Service and proceed with radial seal replacement• Clean breather (refer to table 8) |
| Oil leakage at breather (oil infeed) | <ul style="list-style-type: none">• Incorrect service position• Oil level too high• Wrong lubricant (foam formation) | <ul style="list-style-type: none">• Correct service position in accordance with sections 3 and 3.1• Check oil level at room temperature and correct in accordance with section 3.3.3, if applicable• Change oil, refer to section 8.1.2 |
| Oil leaks at screw plugs (oil drain) | <ul style="list-style-type: none">• Screw plugs not properly fastened | <ul style="list-style-type: none">• Check radial seals and tighten screw plugs according to table 8.1.1 |

Table 7: Malfunctions, causes, remedy

Operation instructions

Escalator gear units

FTSST158.1 / FTSST180.1 / FTSST212.1 / FTSST 260.1

8. Maintenance and repair



The stipulated inspection intervals (table 8) mentioned above are part of the conditions of warranty.

All service work may only be performed by qualified and trained personnel.



Work on the gear unit always has to be performed while the gear unit is switched off and protected against accidental start-up (key switch, sign).

CAUTION!

Only use original spare parts by AUMA Drives for repair and maintenance tasks; otherwise a safe function of the gear unit cannot be guaranteed. All warranty and liability claims are void if the maintenance work has not been carried out correctly or if unapproved spare parts have been used.

| Measure | Maintenance interval | Remarks/notes |
|--------------------------------------|---|---|
| Check gear temperature | Every 3 months | Max. permissible temperature at housing: 110 °C In case of higher temperatures, refer to section 7. |
| Check running noise | Every 3 months | In case of changes, refer to sections 3.3.4 and 7. |
| Check oil level | Every 3 months | Refer to sections 8.1.1 and 3.3.3 |
| Check oil quality | Every 3 months | Refer to sections 8.1.1 and 3.3.3 |
| Check gear unit for leak tightness | Every 3 months | |
| Visual inspection of painting | Every 3 months | Damage to the coating of the outer gear unit parts leads to failure of the corrosion protection and has to be touched up immediately. |
| Clean breather | Every 3 months | Clean unscrewed breather with petroleum ether and dry or blow with compressed air. Ensure sufficient ventilation (explosion hazard)! |
| First oil change | After 2,000 operation hours | Refer to section 8.1.2 |
| Further oil changes | After further 15,000 operating hours or 60 months | Refer to section 8.1.2 |
| Clean gear unit | Every 12 months | Excessive water pressure and concentrated cleaning agents are not permitted for eliminating possible contamination. |
| Check fastening screws for tight fit | Every 12 months | Refer to section 5.1 |

Table 8: Corrective action and intervals

8.1. Description of maintenance work

8.1.1. Oil level and status monitoring



Oil and oil filling level may only be checked once gear unit has cooled down and is at standstill.

Checking the lubricant properties:

Open screw plug at oil drain (for position, refer to section 3.1 and dimension sheets in sections 10 to 12) and drain a small quantity. Seal oil drain according to specified tightening torque (table 8.1.1) (Caution: Fit sealing ring again!). Check oil quality for colour and solid contents or contamination. If required, change oil (refer to section 8.1.2) .

Operation instructions

Escalator gear units

FTSST158.1 / FTSST180.1 / FTSST212.1 / FTSST 260.1

Oil level monitoring:

Remove breather with oil dipstick (refer to section 3.1), unscrew and wipe remaining oil off the oil dipstick. The oil level can only be read off again, once the breather has been completely screwed in and removed again (refer to section 3.3.3). Correct oil level in case of deviations (refer to section 8.1.2 steps 5 & 6).

 Exclusively use lubricant of the same type (refer to name plate!) for refilling. Mixing oils of various types and manufacturers is not permissible (for selection, refer to table 3.3.3-1). Mineral oils in particular must not be used.

Finally, the breather valve has to be screwed in again, refer to table 8.1.1 for the required tightening torque. Replace damaged sealing rings.

 After long-term operation under full load, the oil level might slightly exceed the permissible maximum. In this case, oil must not be drained!

| Size | Tightening torque of the breather [Nm] | Width s of hexagon socket of the screw plug at the oil drain [mm] | Tightening torque of screw plug at the oil drain [Nm] |
|------------|--|---|---|
| FTSST158.1 | 34 | 8 | 34 |
| FTSST180.1 | 34 | 8 | 34 |
| FTSST212.1 | 34 | 17 | 100 |
| FTSST260.1 | 34 | 17 | 100 |

Table 8.1.1: Tightening torques of screw plugs and breather

8.1.2. Oil change

Oil change has to be performed shortly after shut-down while still **at service temperature** (housing surface is hand warm). Otherwise complete draining cannot be ensured due to lack of viscosity.

 **Heat resistant gloves must imperatively be worn to avoid burns due to hot draining oil!**

1. Place collecting basin underneath the oil draining screw plug.
2. Unscrew oil draining screw plug and oil filling screw.
3. Drain oil completely. If required, rinse gear unit with low-viscosity (and compatible) oil. Possible bronze flakes are uncritical.
4. Seal oil drain: Tighten oil draining screw plug and sealing ring with tightening torque according to table 8.1.1.
5. Refill new oil (refer to section 3.3.3) up to required filling level (refer to section 8.1.1 "Oil level monitoring").
6. Seal oil infeed with screw plug (for tightening torque refer to table 8.1.2).
7. Contain spilled oil using a suitable agent and dispose of used oil according to national regulations.

| Size | Width across flats s of the hexagon socket of the oil filling screw plug [mm] | Tightening torque of the oil filling screw plug [Nm] |
|------------|---|--|
| FTSST158.1 | 17 | 100 |
| FTSST180.1 | 17 | 100 |
| FTSST212.1 | 17 | 100 |
| FTSST260.1 | 17 | 100 |

Table 8.1.2: Tightening torques of oil filling screw plug

Operation instructions

Escalator gear units

FTSST158.1 / FTSST180.1 / FTSST212.1 / FTSST 260.1

8.1.3. Cleaning the breather

The breather can be dismantled to clean the filter. After opening the lock, the filter insert can be removed. Cleaning can be done using compressed air.

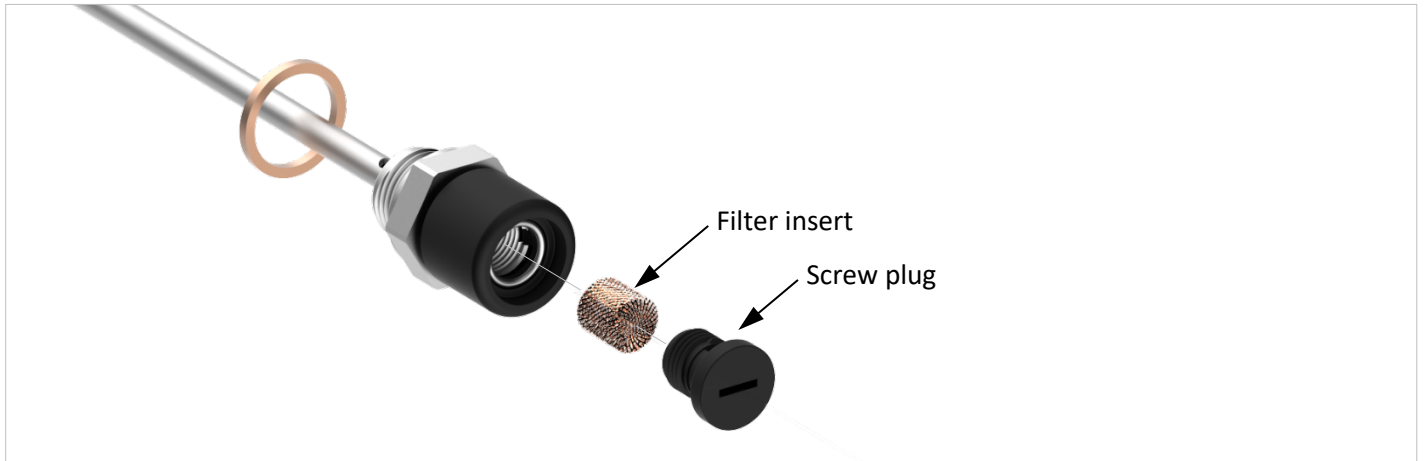

Figure 8.1.3: Dismantling of filter

Operation instructions

Escalator gear units

FTSST158.1 / FTSST180.1 / FTSST212.1 / FTSST 260.1

8.2. Spare parts

CAUTION!

Only use original spare parts by AUMA Drives for maintenance work! We will not assume any liability or warranty for damage incurred when using other spare parts than provided by AUMA Drives. Furthermore, use of such products might impair the both characteristics and operational reliability as well as safety of the gear unit. Please indicate the order number or serial number of the gear unit (refer to name plate) when ordering spare parts.

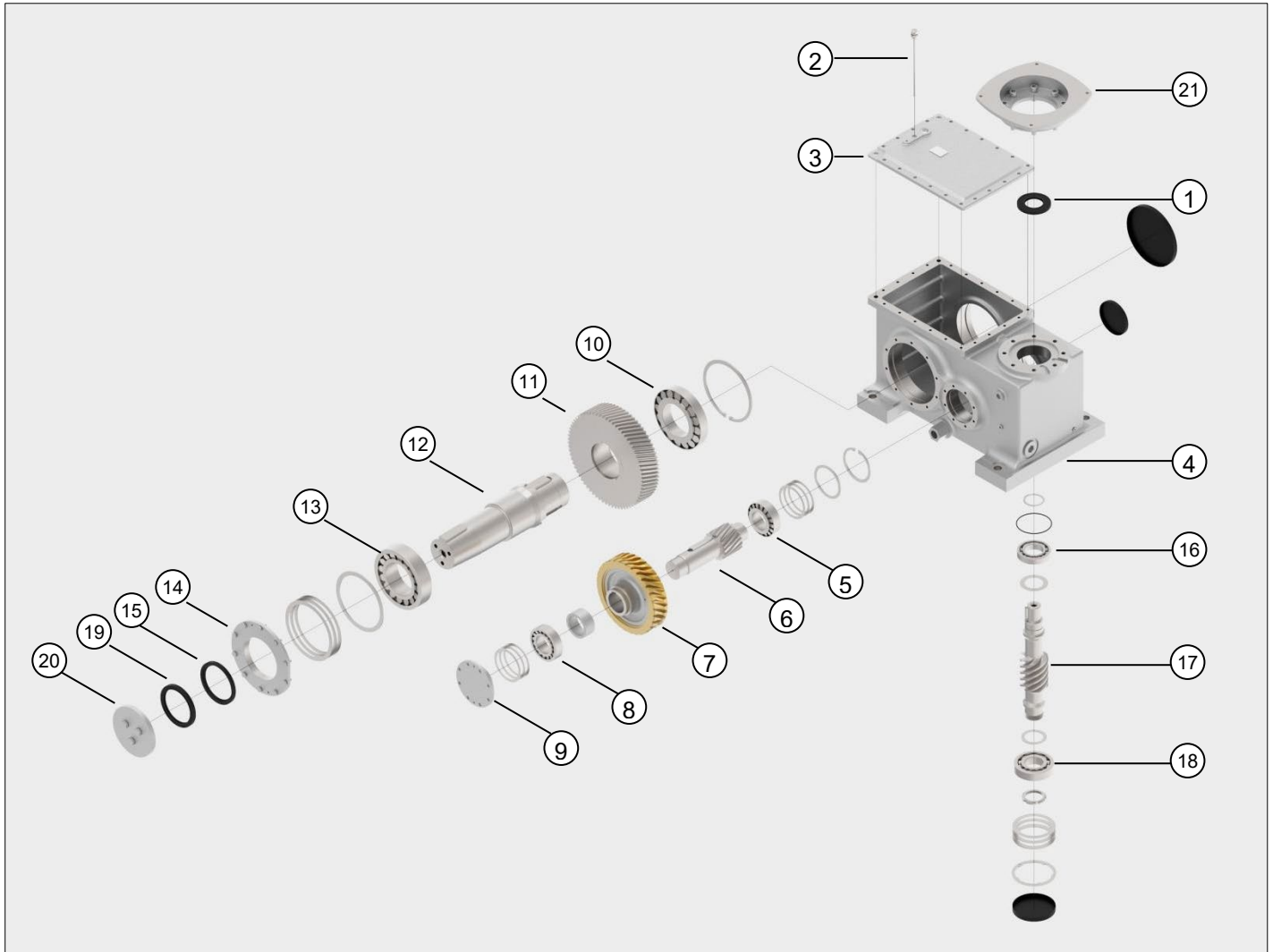

Figure 8.2: Exploded view (example FTSST212.1)

| No. | Spare part designation | FTSST158.1 | FTSST180.1 | FTSST212.1 | FTSST260.1 |
|-----|------------------------------------|---------------------|---------------------|---------------------|--------------------|
| 1 | Radial seal DIN 3760 | D005.423 + K013.005 | D005.424 + K013.006 | D005.424 + K013.006 | D005.448+ K013.262 |
| 2 | Breather with oil dipstick | K014.091 | K014.092 | K014.148 | K012.104 |
| 3 | Housing cover | | | | |
| 4 | Housing | | | | |
| 5 | Tapered roller bearings DIN 720 | D052.001 | D052.355 | D052.801 | D005.445 |
| 6 | Pinion shaft | | | | |
| 7 | Worm wheel | | | | |
| 8 | Tapered roller bearings DIN 720 | D052.001 | D052.355 | D052.801 | D005.445 |
| 9 | Bearing cover worm wheel | | | | |
| 10 | Tapered roller bearings DIN 720 | D052.816 | D052.356 | D052.857 | D005.446 |
| 11 | Helical gear | | | | |
| 12 | Output drive shaft | | | | |

Table 8.2: Wear parts

To be continued on following page...

Operation instructions

Escalator gear units

FTSST158.1 / FTSST180.1 / FTSST212.1 / FTSST 260.1

| | | | | | | |
|----|-------------------------------|----------|----------|----------|----------|----------|
| 13 | Tapered roller bearings | DIN 720 | D052.816 | D052.357 | D003.891 | D005.447 |
| 14 | Bearing cover of output drive | | | | | |
| 15 | Radial seal | DIN 3760 | D004.859 | D004.521 | D004.522 | D050.167 |
| 16 | Deep groove ball bearing | DIN 625 | D050.213 | D050.215 | D050.215 | D005.443 |
| 17 | Worm shaft | | | | | |
| 18 | Angular ball bearing | DIN 628 | D052.821 | D052.266 | D052.266 | D005.444 |
| 19 | Radial seal | DIN 3760 | D004.664 | D004.665 | D052.803 | D005.449 |
| 20 | End washer | | | | | |
| 21 | Motor flange | | | | | |

Table (continued) 8.2: Wear parts

9. Disposal

Our gear units have a long service life. However, they have to be replaced at one point in time. Individual components have to be disposed of as follows:



- Housing parts, worm shaft, shafts and roller bearings are to be disposed of as scrap steel
- Parts made of cast iron are also to be handled as scrap steel, in case there is no separate collection.
- Worm wheels made of bronze have to be disposed of separately.
- Greases and oils are hazardous to water and must not be released into the environment. They have to be collected and disposed of according to the relevant environmental provisions (national regulations for waste disposal).

14. Appendix V: Declaration of Incorporation



Drives

AUMA Drives GmbH
Grenzstraße 5
D-01640 Coswig
www.auma-drives.com

Tel. +49 3523 94 60
Fax +49 3523 74 675
info@auma-drives.com

EC Declaration of Incorporation

according to EC machinery directive 2006/42/EC dated 17 May 2006, appendix II B

The manufacturer

AUMA Drives GmbH
Grenzstraße 5
D-01640 Coswig/ Germany

declare herewith that the above mentioned gear units comply in their conception and design as well as in the versions distributed with the basic requirements for safety and health of the EC Directive 2006/42/EC, considering particularly appendix 1, paragraphs 1.1.2, 1.1.3, 1.1.5, 1.3.1, 1.3.7, 1.7.1., 1.7.3, 1.7.4.

With regard to the partly finished machine, the manufacturer commits to submitting the documents to the competent national authority via electronic transmission upon reasonable request. The relevant technical documentation pertaining to the partly completed machinery described in Annex VII, part B has been prepared.

The partly finished machine must not be put into service until the machinery into which the AUMA Drives unit is to be incorporated has been declared in conformity with the provisions of the EC Directive (2006/42/EC).

Description of the partly finished machinery:

- Worm gear units
- Spur gear units
- Worm-spur gear units
- Spur-worm gear units
- Double worm gear units
- Slewing gear units
- Screw jacks
- Cross-helical gears
- Bevel gearboxes
- Planetary gears
- Hypoid gear units
- Hypoid- helical gear units

Applied harmonised standards:

- DIN EN ISO 12100:2011 Safety of machinery
- General principles for design - Risk assessment and risk reduction

Authorised person for technical documentation:

Michael Eleser, Grenzstraße 5, D-01640 Coswig



Coswig 2022-02-07
Ort Date

Markus Weber, Managing Director

Y050.082/EN

This declaration does not contain any guarantees. The safety instructions in product documentation supplied with the devices must be observed. Non-concerted modification of the device components voids this declaration.

AUMA Drives GmbH
Grenzstraße 5
01640 Coswig/Germany
Phone: +49 (0) 3523 94 60
www.auma-drives.com

AUMA Drives Service
Phone: +49 (0) 3523 94 60
Service.driv@auma.com



PM-MS
Y050.081

BA_FTSST158.1_180.1_212.1_260.1_EN_07.2024