

auma[®]

Solutions for a world in motion

Drives

Translation of the German original operation instructions

*Worm gear unit
S40.1-S450.1*



AUMA Drives
Grenzstr. 5
01640 Coswig/Germany
Phone: +49 (0) 3523 94 60
www.auma-drives.com

AUMA Drives Service
Phone: +49 (0) 3523 94 60
service.driv@auma.com

Y050.087
BA_S40.1-450.1_EN_12.2024

Table of contents

1.	Introduction	3
2.	Safety instructions	3
2.1.	Intended use	3
2.2.	Inappropriate or unintended use	4
2.3.	Warnings and notes, symbols and their signification	4
2.4.	Important instructions, basic duties, warranty and liability	4
3.	Technical description	5
3.1.	Design	6
3.2.	Name plate	7
3.3.	Technical data	8
3.3.1.	Service positions S40.1 – S80.1	8
3.3.2.	Service positions S100.1 – S160.1	9
3.3.3.	Service positions S200.1 – S450.1	10
3.3.4.	Gear unit weight	11
3.3.5.	Lubricant	11
4.	Delivery, transport, handling & storage, protection	13
4.1.	Delivery, transport and handling	13
4.2.	Storage and preservation	14
5.	Assembly	15
5.1.	Gear unit assembly	15
5.1.1.	Gear units with open shaft ends (at input drive or output drive)	15
5.1.2.	Gear unit with hollow shaft at output drive (slip on gear unit)	16
5.2.	Mounting a motor	17
6.	Commissioning	18
7.	Operation, malfunctions, causes, remedies	19
8.	Servicing and maintenance	20
8.1.	Description of maintenance work	21
8.1.1.	Oil level and status monitoring	21
8.1.2.	Oil change	21
8.1.3.	Cleaning the air vent	22
9.	Screw tightening torques	23
9.1.	Coarse pitch thread screws	23
9.2.	Screw plugs	23
10.	Spare parts	24
10.1.	Spare parts for sizes S40.1 – S80.1	24
10.2.	Spare parts for sizes S100.1 – S160.1	25
10.3.	Spare parts for sizes S200.1 – S450.1	26
11.	Disposal	27
12.	Appendix I: Declaration of Incorporation	28

1. Introduction

The present operation instructions are part of the scope of supply and should be stored, if possible, near the gear unit where they can easily be accessed. Installation, commissioning and maintenance work may only be performed by qualified personnel who have both read and understood these operation instructions. AUMA Drives shall not be held liable for any damage or failure incurred by non-observance of these instructions.

AUMA Drives worm gear units have been designed in accordance with recognised standards, directives and safety regulations and correspond to the technical status at the time of printing of these operation instructions. We reserve the right to perform technical alterations on the products.

The copyright of these operation instructions remains with AUMA Drives GmbH, hereinafter called "AUMA Drives". The operation instructions shall neither be used completely nor in parts without authorisation nor be made available to third parties without our prior consent.

In case of doubt, uncertainty or queries regarding these operation instruction, please contact AUMA Drives Service:

AUMA Drives Service

Phone: +49 (0) 3523 94 60

service.driv@auma.com

2. Safety instructions

2.1. Intended use

AUMA Drives worm gear units have been designed and developed in accordance with recognised standards, directives and safety regulations and are supplied ready to operate. Machinery Directive 2006/42/EC applies to AUMA Drives worm gear units. They are partly completed machinery to be installed in a machine. The required Declaration of Incorporation of Partly Completed Machinery is included in section 12 of these operation instructions. The machine operator or the machine manufacturer must ensure that all legal requirements, directives, guidelines, national regulations and recommendations with respect to assembly, commissioning and operation are met at the place of installation.

Installation, commissioning and maintenance work must be exclusively performed by qualified personnel. Qualified personnel are persons, who, because of their training, experience and position as well as their knowledge of appropriate standards, regulations, health and safety requirements and working conditions, are authorised by the person responsible for the safety of the equipment to perform the required duties and are therefore aware of, and can report, possible hazards. (Definition of qualified employees according to IEC 364)

AUMA Drives worm gear units may only be operated within the limits and conditions defined in the delivery contract.

Intended use includes observance of the operation instructions or observance of the instructions and specifications included. Furthermore, fulfilment of the legal provisions on occupational health and safety and the prevention of accidents, as well as heeding of safety instructions and warning signs attached to the product to avoid both personal injuries and property damage must be ensured.

Operation instructions

Worm gear unit
S40.1 – S450.1

2.2. Inappropriate or unintended use

Any uses other than those indicated in section 2.1 are either inappropriate or unintended. AUMA Drives shall not assume any liability for personal injuries or property damage incurred from this use.

Inappropriate or unintended use includes among others:

- Use in potentially explosive atmosphere
- Use outside technically and contractually agreed limits (output speeds, power, torques, ambient conditions)

Improper use furthermore includes:

- Operation without oil filling or with lubricants other than those specified
- Operation without air vent.
- Opening the gear unit when installed. During the warranty period, gear units may only be opened with prior consent of the manufacturer, otherwise any warranty claim will be void.
- Any modifications on the gear unit and in particular those impairing operational safety and reliability

2.3. Warnings and notes, symbols and their signification



Symbol	Signification
	Indicates safety instructions which have to be observed to avoid personal injuries (injuries, death).
	Indicates safety instructions which have to be observed to avoid damage at the gear unit.
	General instructions, hints.

Table 2.3: Warnings and symbols

2.4. Important instructions, basic duties, warranty and liability

- The machine manufacturer/operator has to ensure that all specifications and instructions have been read, understood and heeded to:
 - Avert threats to life or physical condition
 - ensure operational safety of the gear unit and
 - Avoid both installation downtimes and damage to the environment
- The plant manufacturer is obliged to include these operation instructions in his/her own operation instructions.
- The machine manufacturer/operator shall be held liable for expert installation (assembly), maintenance and operation of the AUMA Drives worm gear unit. This work may only be performed by qualified and trained personnel.
- Work always has to be performed while the gear unit is switched off and protected against accidental start-up (key switch, sign).
- In case of detected defects as well as for malfunctions such as increased noise levels, oil leakage, rising operating temperature, etc., the gear unit must be shut down immediately. All defects must be remedied before restarting the equipment.
- During the warranty period, the gear units may only be opened with AUMA Drives' prior consent.

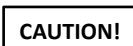
Operation instructions

Worm gear unit
S40.1 – S450.1

- Spare parts must generally be ordered with AUMA Drives.
- Prior to using the gear unit, the data on the name plate has to be compared with the data of the collateral documents (delivery note, order acknowledgement, test report, etc.) for compliance.
- Welding at the gear unit is not permitted and the gear unit must not be used for protective earth connection.
- Revolving and rotating parts must be protected against accidental contact.
- The plant manufacturer or plant operator is responsible for implementing required protective measures on site, such as enclosures, barriers, or personal protective equipment for the staff.
- Under certain operation conditions, the surface temperature of the gear unit may rise up to 110°C. Danger of burns!
- Danger of burns due to hot oil when changing oil.
- Cleaning with a high pressure cleaner is not permitted.

Failure to observe the specifications indicated entails complete exclusion of liability and warranty expires. Consequential damage of inappropriate use can include property damage, personal injuries and even death.

3. Technical description

AUMA Drives gear units of S.1 type range are classified as single-stage worm gear units. characterised by extremely low noise, high efficiency, utmost reliability and long service life.



AUMA Drives worm gear units are not self-locking as standard.

Self-locking means that worm shaft start-up is not possible in spite of the driving worm wheel. External influences such as vibration can limit or even cancel the self-locking effect. Among others, self-locking depends on the reduction ratio (or the pitch angle of the splines), the lubricant as well as the operating and ambient temperatures. In case of drive tasks requiring self-locking, it must always be tested whether installation of a backlash stop or a brake is feasible as better solution. Self-locking gear units do not replace brakes. If self-locking is required, please contact AUMA Drives.

Section 3.1 provides a schematic description of the AUMA Drives worm gear units. Major sub-assemblies are designated.

3.1. Design

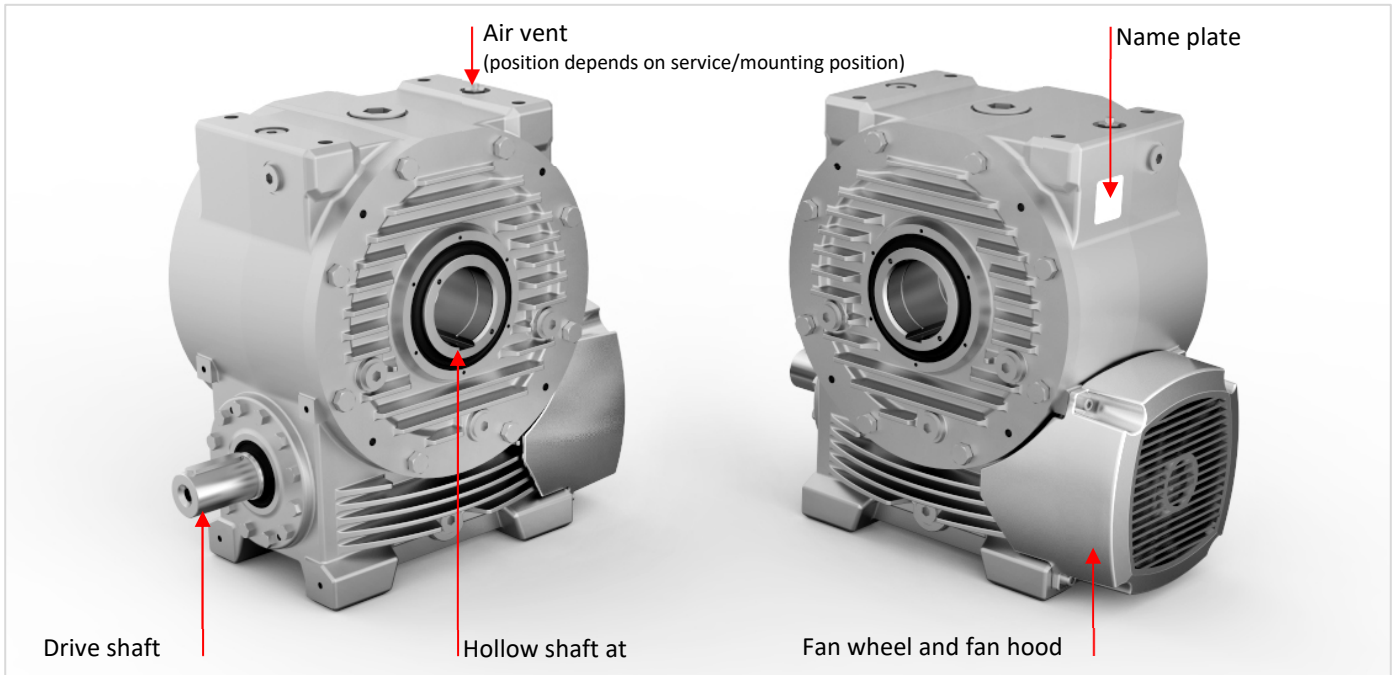

Figure 3.1-1: Set-up of basic version (shaft at input, hollow shaft at output) with the example of 250.1 in service position B3



In addition to basic versions, optional plant-specific equipment is available, such as flanges, output drive shafts, torque reaction levers, etc.

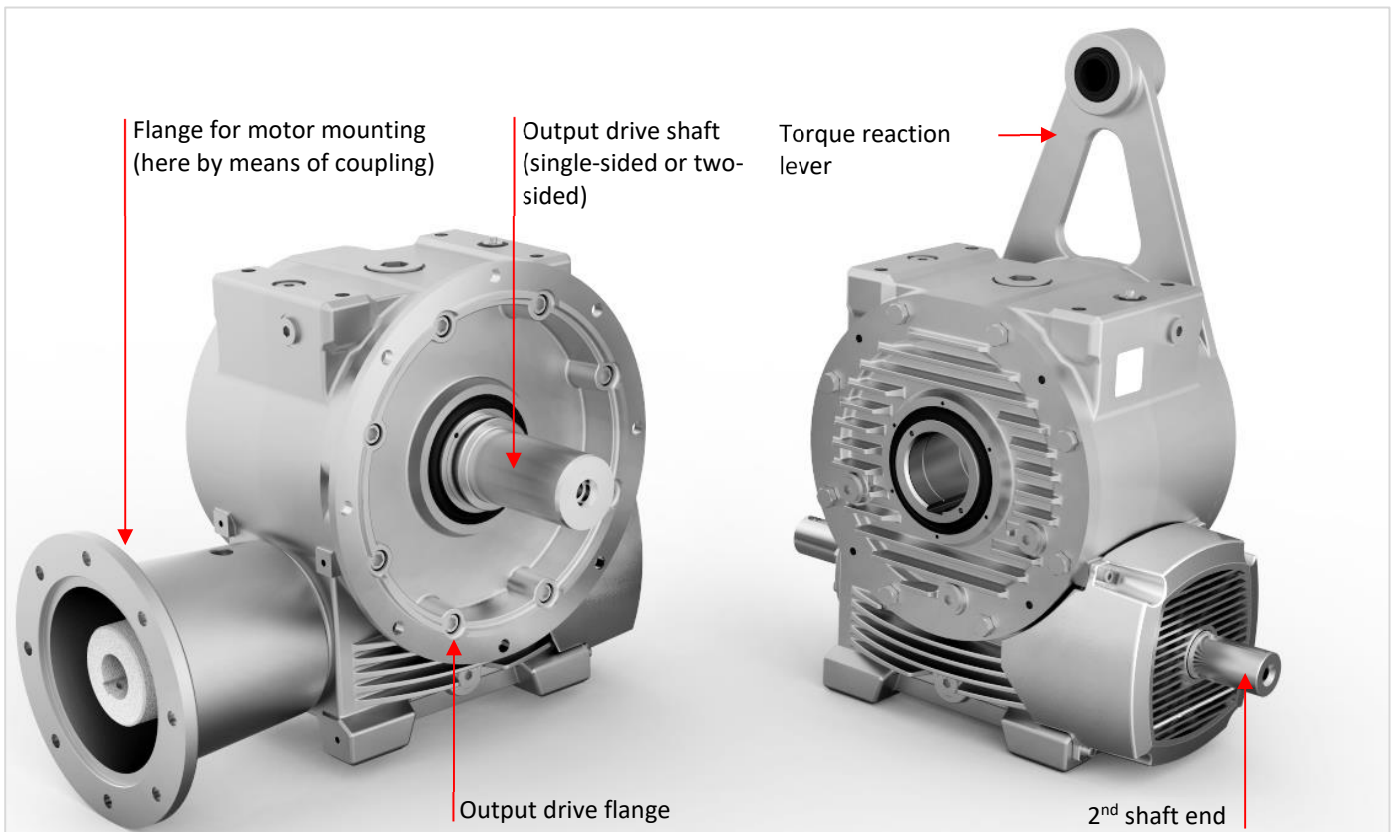

Figure 3.1-2: Mounting options (extract) with the example of S250.1

Operation instructions

Worm gear unit

S40.1 – S450.1

auma[®]

Solutions for a world in motion

3.2. Name plate

The following data is provided on the name plate attached to the gear unit.

auma		AUMA Drives GmbH, D-01640 Coswig	
Type / size / parts list	Type: _____	Service position	_____
Serial number	No: _____ CO _____	AUMA Drives order number	_____
Delivery week/year [WWYY]	$T_{2max} =$ _____ Nm	Reduction ratio	Ratio: _____
Maximum output torque	$n_2 =$ _____ rpm	Ambient temperature	Temp.: _____
Output speed	Lub.: _____	Lubricant quantity	_____
Lubricant	Item No.: _____	Weight	m= _____ kg
Customer article number	_____	Enclosure protection	_____
Reserved	_____		
Made in Germany			

auma		AUMA Drives GmbH, D-01640 Coswig	
Type / size / parts list	Type: _____	Service position	_____
Serial number	No: _____ CO _____	AUMA Drives order number	_____
Delivery week/year [WWYY]	$T_2 =$ _____ Nm	Reduction ratio	Ratio: _____
Nominal output torque	$n_1 =$ _____ rpm	Ambient temperature	Temp.: _____
Input speed	Lub.: _____	Lubricant quantity	_____
Lubricant	Item No.: _____	Weight	m= _____ kg
Customer article number	_____	Enclosure protection	_____
Reserved	_____		
Made in Germany			

auma		AUMA Drives GmbH 01640 Coswig/Germany	
Type / size / parts list	Type: _____	Service pos. _	Enclosure protection
Serial number	No: _____ CO _____	AUMA Drives order number	_____
Delivery week/year [WWYY]	$T_2 =$ _____ Nm	Reduction ratio	Ratio: _____
Nominal output torque	$n_1 =$ _____ rpm	Ambient temperature	Temp.: _____
Drive speed	Lub.: _____	Lubricant quantity	_____
Lubricant	Item No.: _____	Weight	m= _____ kg
Reserved	_____		

3.3. Technical data

3.3.1. Service positions S40.1 – S80.1

The illustrations below show possible service positions as well as the respective position of air vent and oil draining screw. Please refer to table 3.3.5-2 for required oil quantities.

<p>B3</p>	<p>Output drive shaft horizontal, Drive shaft horizontal bottom</p> 	<p>B6</p>	<p>Output drive shaft horizontal, Drive shaft vertical bottom</p> 
<p>B8</p>	<p>Output drive shaft horizontal, Drive shaft horizontal top</p> 	<p>V5</p>	<p>Output drive shaft vertical bottom, Drive shaft horizontal</p> 
<p>B3I</p>	<p>Output drive shaft horizontal, Drive shaft vertical top</p> 	<p>V5II</p>	<p>Output drive shaft vertical top, Drive shaft horizontal</p> 
<p style="text-align: center;">● Air vent and oil filling ● Oil drain</p>			

Figure 3.3.1: Service positions S40.1 – S80.1

Operation instructions

Worm gear unit
S40.1 – S450.1

3.3.2. Service positions S100.1 – S160.1

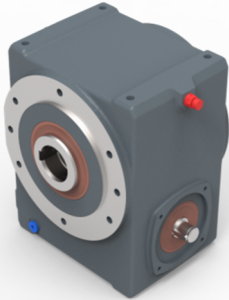
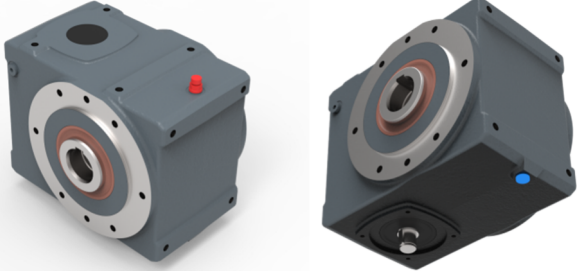
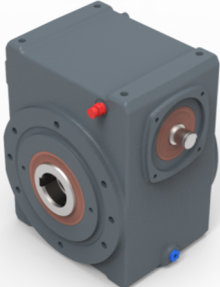
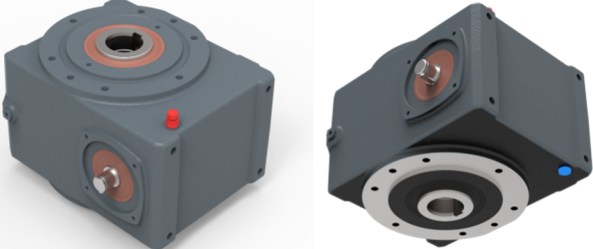
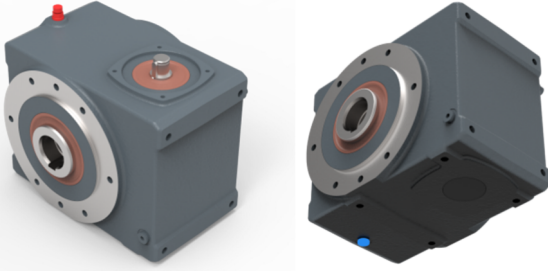
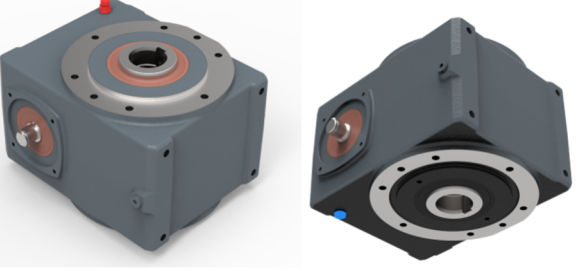
The illustrations below show possible service positions as well as the respective position of air vent as well as the oil filling level and oil draining screw. In certain cases, an oil dipstick at air vent replaces the function of the oil level screw. Please refer to table 3.3.5-2 for required oil quantities.

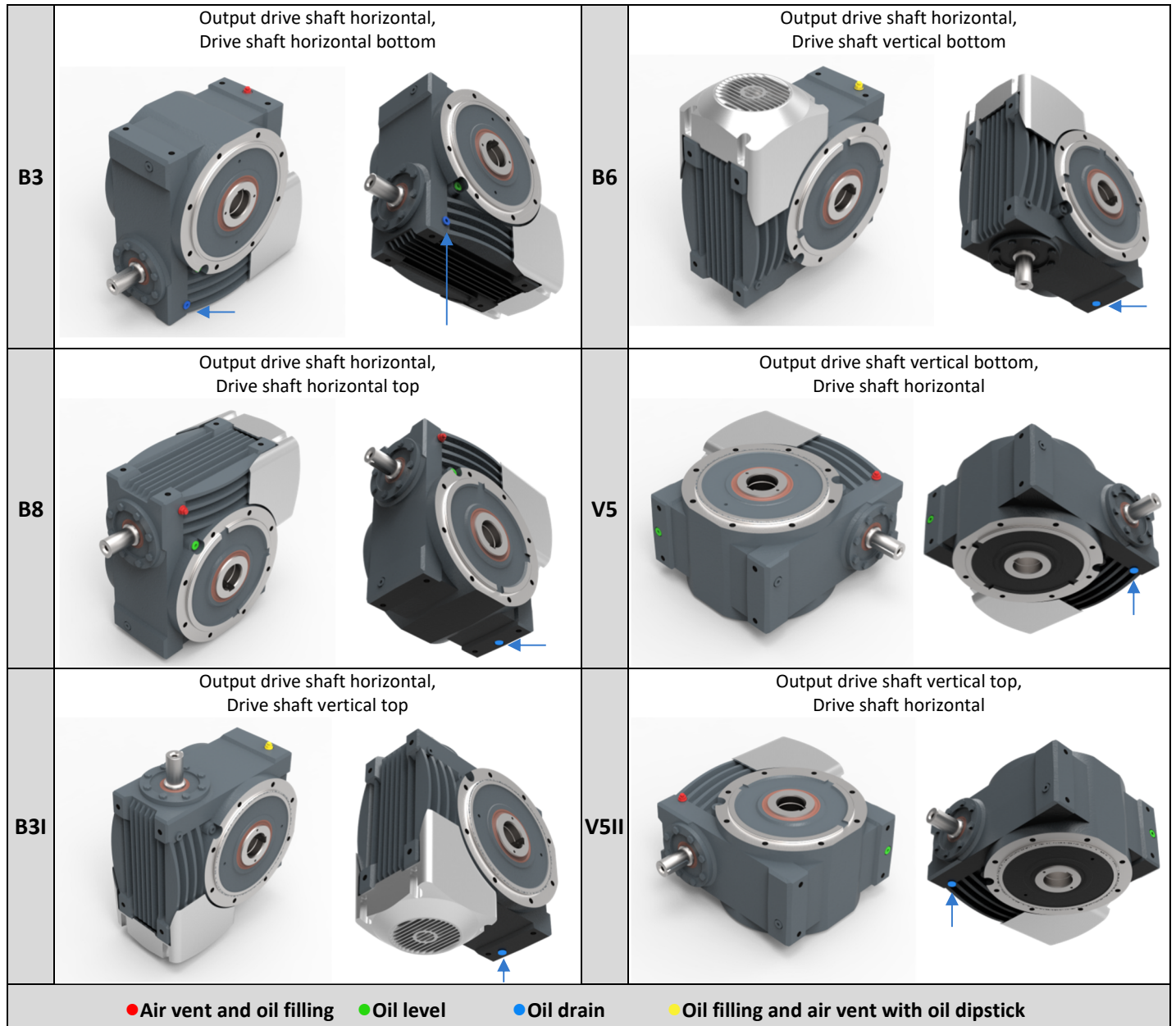

Figure 3.3.2: Service positions S100.1 – S160.1

CAUTION!

Depending on the application and deployment conditions, a deviating oil quantity or deviating oil level might be required with regard to the indications specified in the operation instructions. Respective information is available in the contractual documents as well as on the name plate. In these instances, the position of oil filling screw and oil level screw can also differ from this representation.

3.3.3. Service positions S200.1 – S450.1

The illustrations below show possible service positions as well as the respective position of air vent as well as the oil filling level and oil draining screw. Please refer to table 3.3.5-2 for required oil quantities.

<p>B3</p>	<p>Output drive shaft horizontal, Drive shaft horizontal bottom</p> 	<p>B6</p> <p>Output drive shaft horizontal, Drive shaft vertical bottom</p> 
<p>B8</p>	<p>Output drive shaft horizontal, Drive shaft horizontal top</p> 	<p>V5</p> <p>Output drive shaft vertical bottom, Drive shaft horizontal</p> 
<p>B3I</p>	<p>Output drive shaft horizontal, Drive shaft vertical top</p> 	<p>V5II</p> <p>Output drive shaft vertical top, Drive shaft horizontal</p> 
<p style="text-align: center;">● Air vent and oil filling ● Oil level ● Oil drain</p>		

Figure 3.3.3: Service positions S200.1 – S450.1

CAUTION!

Depending on the application and deployment conditions, a deviating oil quantity or deviating oil level might be required with regard to the indications specified in the operation instructions. Respective information is available in the contractual documents (e.g. drawings) as well as on the name plate. In these instances, the position of oil filling screw and oil level screw can also differ from this representation.

Operation instructions

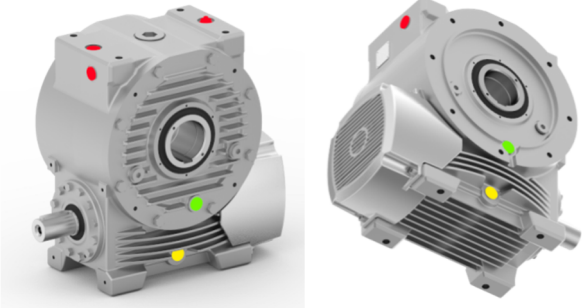
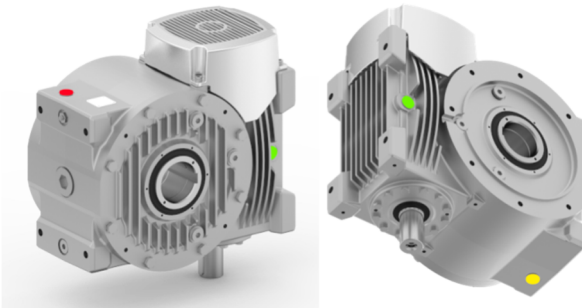
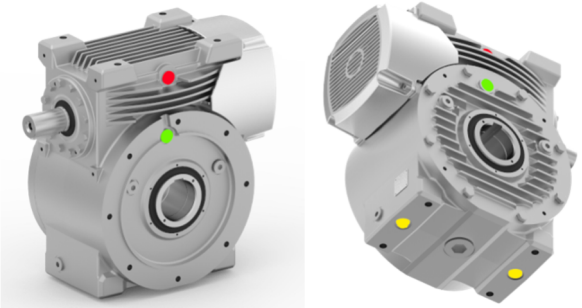
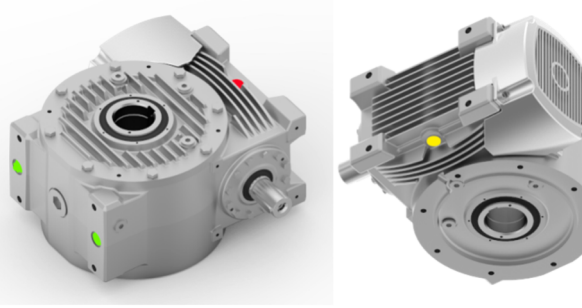
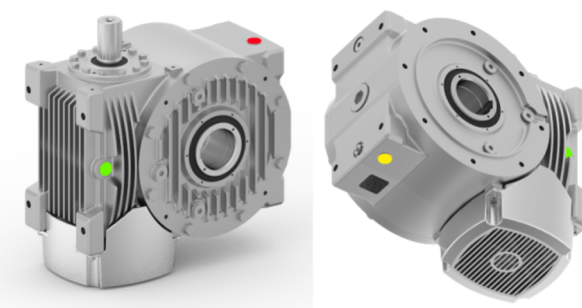
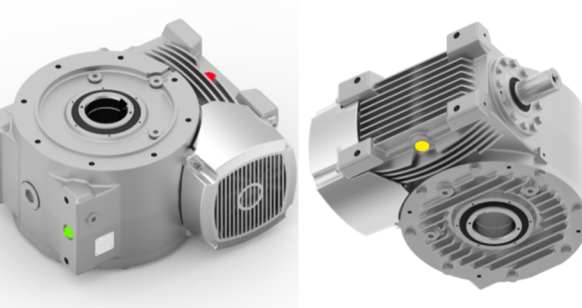
Worm gear unit
S40.1 – S450.1

3.3.4. Gear unit weight

The weights below do not include lubricant filling and are reference values. Cast tolerances as well as various transmission ratios and equipment variants lead to different weights. Due to the large variety of equipment, a complete representation is not possible. Refer to the name plate indication (incl. oil) for the weight of the supplied configuration.

Size	SVA basic version Without oil [kg]
S40.1	5.2
S50.1	11.0
S63.1	14.5
S80.1	26
S100.1	46 ¹⁾
S125.1	84 ¹⁾
S160.1	157 ¹⁾
S200.1	210 ¹⁾

Table 3.3.4: Gear unit weights

Size	SVA basic version Without oil [kg]
S225.1	336 ¹⁾
S250.1	380 ¹⁾
S280.1	525 ¹⁾
S315.1	700 ¹⁾
S355.1	960 ¹⁾
S400.1	1300 ¹⁾
S450.1	1710 ¹⁾

1) incl. fan

3.3.5. Lubricant

The lubrication of splines of AUMA Drives worm gear units is performed as splash lubrication. Unless agreed otherwise, the gear units are supplied with oil filling when leaving the factory. As standard, we use CLP-PG oils (according to DIN 51517-part 3). These fully synthetic oils (polyglycoles) have outstanding temperature-viscosity behaviour and excellent characteristics with regard to corrosion protection, resistance to ageing and wear reduction. For ambient temperatures between –10 °C and +40 °C, oils of ISO viscosity class VG460 must be used. For other ambient conditions, a suitable lubricant has to be selected by AUMA Drives. The table below lists lubricants by different manufacturers. The lubricant used is indicated on the name plate. Gear units without oil filling in the factory have a DIN compliant indication relating to the lubricant to be used and the required viscosity class.

Marking according to DIN 51517-3 and DIN 51519	Klüber	Shell	Mobile	Bechem	Castrol
CLP PG / ISO VG 460	Klübersynth GH 6-460 ²⁾	Omala S4 WE 460	Glygoyle 460	Berusynth EP 460	Alphasyn GS 460

Table 3.3.5-1: Lubricants

2) Factory standard lubricant

CAUTION!

AUMA Drives shall not assume any warranty for the perfect suitability of all listed lubricants.



For certain applications, different lubricants (mineral oils, lubricating greases) might be used. Refer to name plate or contract documents (e.g. drawings) for the lubricant actually used.



Mixing oils of various classes, types and manufacturers is not permissible. Refer to name plate for the lubricant actually used.

Operation instructions

Worm gear unit

S40.1 – S450.1

auma[®]*Solutions for a world in motion***CAUTION!**

The table below shows the required oil quantities. These values are reference values. The filling level (of the cooled down oil) within the gear unit, defined by oil level screw plugs or markings (max. and min.) on the oil dipstick, is relevant – refer to sections 3.3.1 to 3.3.3.

Size	Service position					
	B3	B8	B3I	B6	V5	V5II
S40.1	0.18	0.28	0.30	0.30	0.20	0.20
S50.1	0.45	0.75	0.65	0.65	0.55	0.55
S63.1	0.63	1.10	1.00	1.00	0.75	0.75
S80.1	1.30	2.50	2.00	2.00	1.50	1.50
S100.1	1.70	3.80	3.00	3.00	3.00	3.00
S125.1	2.00	6.50	4.00	4.00	4.00	4.00
S160.1	4.20	12.30	8.50	8.50	7.70	7.70
S200.1	8.00	22.00	15.00	15.00	13.50	13.50
S225.1	11.00	26.00	19.00	19.00	19.50	19.50
S250.1	14.00	42.50	29.00	29.00	29.00	29.00
S280.1	18.50	58.00	41.00	41.00	39.50	39.50
S315.1	27.00	75.00	53.00	53.00	53.00	53.00
S355.1	36.00	110.00	75.00	75.00	75.00	75.00
S400.1	44.00	148.00	98.00	98.00	98.00	98.00
S450.1	68.00	219.00	141.00	141.00	144.00	144.00

Table 3.3.5-2: Lubricant quantity

CAUTION!

Depending on the application and deployment conditions, a deviating oil quantity or deviating oil level might be required with regard to these indications. Respective information is available in the contractual documents as well as on the name plate.

Operation instructions

Worm gear unit
S40.1 – S450.1

4. Delivery, transport, handling & storage, protection

4.1. Delivery, transport and handling

Prior to delivery, all AUMA Drives worm gear units are subjected to final inspection and leave AUMA Drives in perfect condition and suitably packaged according to their destination. Upon receipt, the delivery has to be inspected for completeness and possible transport damage. Notify the forwarding company or the customer service of AUMA Drives of any possible defects. Commissioning the gear unit might not be permitted.

CAUTION!

As standard, AUMA Drives worm gear units are equipped with air vents. The air vents are either mounted (version with air vent as valve) or included separately with the delivery (version of air vent as filter). In the latter case, the air vent must be mounted prior to commissioning (refer to section 6 “Commissioning”). A respective note label is fixed to the gear unit.



If possible, the gear units are to be stored and transported in service position (refer to references in sections 3.3.1 through 3.3.3). In certain versions, service position storage and transport must be **imperatively heeded**. In these instances, the gear units are marked with the respective note label.



Only use lifting appliances and load suspension equipment with sufficient bearing capacity for transport! For the overall weight of the gear unit, refer to the name plate. Reference values can also be found in section 3.3.4. **The load is borne by respectively two suitable eyebolts. Ensure that they have been firmly screwed to the housing. Figure 4.1 shows an example of how to use the eyebolts for transport in service position B3. For other service positions, further threaded bores might be available in the housings.**

CAUTION!

The gear unit must not be handled via the threaded holes in the drive shafts and output drive shafts on the face side, nor via the fan housing. Handle and transport with care to prevent damage. Hits and blows to the shaft ends might cause damage within the gear unit.



Figure 4.1: Lashing points

Size	Thread size for transport eyebolts	Size	Thread size for transport eyebolts
S40.1	M6	S200.1	M20
S50.1-S63.1	M8	S225.1-S250.1	M24
S80.1	M10	S280.1-S315.1	M30
S100.1	M12	S355.1-S450.1	M36
S125.1-S160.1	M16		

Table 4.1: Thread sizes for transport eyebolts

4.2. Storage and preservation

The storage or protection period commences immediately after delivery of the gear unit.

Unless agreed otherwise, AUMA Drives worm gear units are supplied with lubricant filling when leaving the factory. Consequently, all inside parts are preserved for 24 months. Inside parts of gear units supplied without oil filling are provided with corrosion protection for 12 months. Outer parts with metallic uncoated surface such as shaft ends, hollow shafts and mounting surfaces of flanges have been treated with corrosion protection, providing protection for six months. After expiry of these periods, a new layer of corrosion protection agent has to be provided.

CAUTION!

Prior to mounting or installation, remove the corrosion protection agent of outer parts using conventional cleaning agents. The cleaning agent must not come into contact with radial seals!



Ensure sufficient ventilation while removing the corrosion protection agent. Due to potentially explosive atmospheres, open fire is not permitted.

The standard outer factory coating (top coat based on polyurethane) is resistant to weak chemicals such as oils, resistant to mechanical impacts and temperature resistant up to 150 °C. Damage to the coating layers leads to failure of the corrosion protection and has to be touched up immediately. Sand blasting of the gear unit is not permitted.

The gear units should only be stored in closed and dry rooms. The impact of solvents and solvent vapours, fuel, acids, rubber thinner or other chemicals should be avoided, as well as direct sunlight, relative humidity >70 % and significant temperature variations. It is recommended to refrain from using plastic films containing softeners.



Gear units must be stored on levelled base plates, protected against vibration, and must not be stacked on top of each other.



Should the storage locations or rooms be subject to major temperature fluctuations, the relative humidity exceed 70% or gear units be stored for a longer period (>24 months), we recommend the following measures:

- Fill gear unit completely with oil (refer to table 3.3.5-1)
- Check oil quality (water contents) on a regular basis
- Seal gear unit airtight in VCI film and include desiccant bags.
- Regularly inspect gear unit with regard to corrosion on outer and uncoated parts.
- Regularly check the gear units for leakage at radial seal.

CAUTION!

After longer storage periods, the lubricant quality (refer to section 8.1.1) and the condition of the radial seals are to be checked prior to commissioning, and be replaced if required. Avoid damage of sealing ring seat at shaft. Furthermore, the oil filling level must be checked (refer to section 8.1.1) and possibly be adjusted to the required level (refer also to table 3.3.5-2). When using other corrosion protection oils than those specified (table 3.3.5-2) for protection, thoroughly rinse gear unit prior to lubricant filling.

5. Assembly

5.1. Gear unit assembly



The safety instructions in section 2 must be observed.

The following conditions must be met for installing the worm gear unit:

- These operation instructions were completely read and understood by the assembly personnel.
- Suitable lifting devices are available in sufficient quantity.
- The data on the name plate and the application must correspond to the contractually agreed values (reduction ratio, output speed, etc.).
- The gear unit must not be damaged.
- Unless agreed otherwise, the ambient temperature must be between -10 °C and $+40\text{ °C}$.
- The environment of the installation site must be free of chemicals, acids, gases, etc., unless agreed otherwise
- The gear unit must not be exposed to heat accumulation and waste heat from other devices.
- Air vent valve (including oil dipstick) and oil draining screw plug must be freely accessible for maintenance work
- The corrosion protection agent must be removed from shaft ends and mounting faces (flanges).
- Machine frame:
The machine frame must be designed to support the specified weights and driving forces so that no additional loads resulting from distortion or twisting can act on the gear unit. Ensure that all mounting faces are flush on the machine frame. Non-observance might cause damage on and within the gear unit.

Welding at the gear unit is not permitted and the gear unit must not be used for protective earth connection!



Should any questions or problems arise during installation, please contact the AUMA Drives service (for contact details refer to cover page of these operation instructions).

5.1.1. Gear units with open shaft ends (at input drive or output drive)

CAUTION!

Gear units with free shaft end have to be placed on a suitable basis together with the driven machine. **To comply with safe operation and low noise, shafts must be carefully aligned. Housing and shaft torsions must be avoided. Alternatively, we recommend using elastic couplings or articulated shafts.**

Gear units with output drive flange can be directly flanged to the driven machine. However, simultaneous fixture of the gear unit on a foundation is not permitted.

For fixing the gear unit, screws of strength class 8.8 are required. All screws have to be fitted applying the required torque (refer to table 9.1).

When mounting couplings, observe the collateral operation and mounting instructions of the coupling manufacturer. The use of flexible couplings to compensate for small inaccuracies in assembly is recommended. Couplings with a circumferential speed up to 20 m/s are static and dynamic balancing has to take place for higher circumferential speeds.

Operation instructions

Worm gear unit

S40.1 – S450.1

CAUTION!

Consideration must be given to the permissible radial forces at the input shaft and output shaft ends when using rigid coupling units and elements which generate radial force, such as pulleys, toothed wheels, etc. The drive and output elements can be mounted by means of a fitting tool (refer to fig. 5.1.1) or by heating the appropriate part (≤ 120 °C; wear heat-resistant gloves!). **Imperatively refrain from mounting applying hammer blows. This could lead to damage at tooth flanks, ball bearings, housing and shaft.** Thoroughly clean gear unit shaft and bores of drive and output drive elements prior to mounting.

We recommend applying a corrosion protection agent (e.g. Gleitmo800 by Fuchs) to the shaft(s) of the gear unit(s) to prevent tribocorrosion.

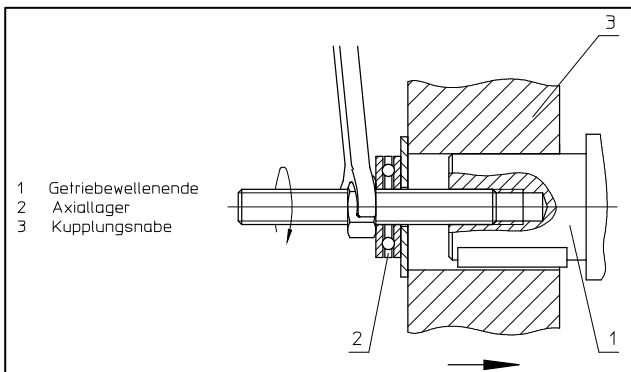

Figure 5.1.1: Fitting tool

5.1.2. Gear unit with hollow shaft at output drive (slip on gear unit)

Gear unit with hollow shaft at the output drive can be placed directly on the shaft of the driven machine and be axially secured.

CAUTION!

For gear units fastened and axially secured via output drive flange, ensure that the gear side mounting face is perpendicular to the axis of the driving machine to avoid distortion of gear unit and driven machine as well as resulting additional bearing loads. For fixing the gear unit, screws of strength class 8.8 are required. All screws have to be fitted applying the required torque (refer to table 9.1). Fixing the gear unit onto a foundation while positioning the machine shaft in proximity of the gear unit must be imperatively avoided.

CAUTION!

For gear units where reaction torque is not absorbed by a flange but by means of a torque reaction lever, it is recommended to fix this torque reaction lever at the driven machine side to avoid additional bending loads. For fixing the torque reaction lever to the gear unit housing, screws of strength class 8.8 are required. All screws have to be fitted applying the required torque (refer to table 9.1). The use of elastic sleeves is recommended to protect against torque blows and torsion. The fastening bolt should be fixed on both sides:

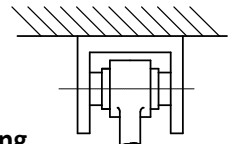

Axial securing of the gear unit on the shaft of the driven machine is either done via a retaining ring and/or end disc with screw. The axial securing can also be done using shrink discs. Clamping screws may not be tightened prior to shaft mounting. This could lead to plastic deformations of the hollow shaft. In general, observe the assembly instructions of the shrink disc manufacturer while considering the following steps:

Operation instructions

Worm gear unit

S40.1 – S450.1

Mounting the shrink disc:

1. Remove spacers (if available) between outer rings
2. Softly tighten screws by hand. The inner ring must still turn.
3. Slightly grease the hub mounting spot for shrink disc.
4. Thoroughly grease hollow shaft bore and driven machine in the press zone.
5. Mount shaft or slip on gear unit onto the driven machine. Make sure to make full use of the shrink connection zone.
6. Evenly tighten clamping screws one after the other (not crosswise!) in clockwise direction. Several turns are required prior to reaching the screw tightening torque.
7. To prevent slipping, the position between solid shaft of the driven machine and hollow shaft of the gear unit must be marked.

Disassembly of shrink disc:

1. Evenly loosen clamping screws one after the other to avoid jamming of the inner ring.
2. Loosening the flanges from the cone of the inner ring.
3. Disassembly of shaft or removing slip on gear unit from driven machine.



We recommend applying a corrosion protection agent (e.g. Gleitmo800 by Fuchs) to the shaft of the driven machine to prevent tribocorrosion.

5.2. Mounting a motor

CAUTION!

The motor is mounted using motor flange and coupling. The use of flexible couplings to compensate for small inaccuracies in assembly is recommended. When mounting couplings, observe the collateral operation and mounting instructions of the coupling manufacturer. For fixing the motor to the gear unit, screws of strength class 8.8 are required. All screws have to be fitted applying the required torque (refer to table 9.1).

CAUTION!

When mounting the motor via a hollow gear drive shaft, ensure that the motor shaft and the mounting face of the motor shaft are perpendicular to avoid distortion and the resulting bearing load. Consequently, AUMA Drives recommends the use of motors for which shape and position tolerances are reduced by 50 % according table 3 of EN 50347:2001 Prior to mounting, thoroughly clean motor shaft and hollow bore of gear unit drive shaft. Apply suitable anti-seizing compound (e.g. Gleitmo800 by Fuchs) to avoid frictional corrosion. For fixing the motor to the gear unit, screws of strength class 8.8 are required. All screws have to be fitted applying the required torque (refer to table 9.1).

CAUTION!

Do not apply hammer blows for assembly. This might damage the splines, roller bearings and the shafts.



Heed operation instructions of the motor manufacturer for electrical connection!

6. Commissioning



The safety instructions in section 2 must be observed.



Commissioning of the gear unit is only permitted once the machine manufacturer/operator has integrated the gear unit in the machine and when complying with product specific European directives by affixing the CE mark on the machine and following the confirmation about the safety of the system put on the market.

CAUTION!

Prior and during commissioning, the following steps have to be performed:

- According to legal regulations, rotating parts must be protected by the user against unintentional contact.
- Check the air vent for blocking or pollution. Insufficient or inappropriate ventilation during operation leads to an increased internal pressure which will in turn cause leakage.
- If the air vent is supplied separately with the delivery, mount the air vent at the provided position (refer to dimensions/drawings or references in sections 3.3.1 through 3.3.3 of the present operation instructions). For this, remove the transport screw plug and fasten the air vent according to tightening torque specified in table 8.1.1.
- Check oil filling level → section 8.1.1
- Check oil quality → section 8.1.1
- Check screw tightening torques → section 9
- Screws which must not be reused due to damage and wear have to be replaced by new ones of the same property class and type.
- During test run, check for unusual noise and vibration, formation of smoke or vapour as well as the service temperature (gear unit surface up to approx. 70 °C), in particular at the bearing.
- Then check the radial seals for leakage.



AUMA Drives worm gear units achieve their full performance and optimum efficiency in well run-in condition and at service temperature. We recommend running in each gear unit with no load for some time first and then at approx. 50% of the rated load for several hours. If operation at partial load is not possible, the gear should be repeatedly stopped and cooled down once an oil temperature of approx. 80 °C – 90°C has been reached. During running in, check for unusual noise and vibration, formation of smoke or vapour as well as the service temperature (gear unit surface up to approx. 70 °C). For gear units operated in alternate mode, running in is required separately for both rotational directions. After running in, check gear unit for leakage.

Operation instructions

Worm gear unit
S40.1 – S450.1

7. Operation, malfunctions, causes, remedies

Gear units must be monitored during operation. Special attention should be paid to unusual running noise, increased service temperatures and possible oil leakage.

CAUTION!

In case of irregularities and when eliminating malfunctions, the gear unit must be shut down immediately and the safety instructions of section 2.4 have to be observed. The equipment has to be protected against accidental start-up.



During the warranty period, maintenance work may exclusively be carried out by AUMA Drives. If malfunctions occurring at a later date cannot be located or the effort required for repair would be excessive, please contact the AUMA Drives service technicians.

Fault	Possible causes	Remedy
Unusual running noise/vibration	<ul style="list-style-type: none">• Damage to splines or bearing• Changed bearing backlash• Oil level too low	<ul style="list-style-type: none">• Contact AUMA Drives Service• Contact AUMA Drives Service• Refill oil and check gear unit for leakage
Unusual blows/vibration	<ul style="list-style-type: none">• Defective motor coupling• Gear support worked loose	<ul style="list-style-type: none">• Replace coupling• Tighten fastening screws according to section 5.1
Increased operating temperature	<ul style="list-style-type: none">• Heat accumulation and /or waste heat from other devices• Oil level too low• Outdated/contaminated oil• Impaired passive cooling	<ul style="list-style-type: none">• Contact AUMA Drives Service• Check oil level at room temperature and correct in accordance with section 3.3.5, if applicable• Change oil• Cleaning the housing surface and the fan hood
Oil leaks at gear unit	<ul style="list-style-type: none">• Damaged radial seals• Clogged air vent	<ul style="list-style-type: none">• Contact AUMA Drives Service and proceed with radial seal replacement• Clean air vent (refer to table 8)
Oil leakage at air vent (oil infeed)	<ul style="list-style-type: none">• Incorrect service position• Oil level too high• Wrong lubricant (foam formation)	<ul style="list-style-type: none">• Correct service position according to section 3.3• Check oil level at room temperature and correct in accordance with section 3.3.5, if applicable• Change oil, refer to section 8.1.2
Oil leaks at screw plugs (oil drain)	<ul style="list-style-type: none">• Screw plugs not properly fastened	<ul style="list-style-type: none">• Check radial seals and tighten screw plugs according to table 8.1.1

Table 7: Malfunctions, causes, remedy

Operation instructions

Worm gear unit
S40.1 – S450.1

8. Servicing and maintenance

AUMA Drives gear units will reliably operate for several years in nominal operation. However, after commissioning, regularly perform checks, cleaning and maintenance.



The stipulated inspection intervals (table 8) mentioned above are part of the conditions of warranty.

All service work may only be performed by qualified and trained personnel.



Work on the gear unit always has to be performed while the gear unit is switched off and protected against accidental start-up (key switch, sign).

CAUTION!

Only use original AUMA Drives spare parts for repair and maintenance tasks; otherwise a safe function of the gear unit cannot be guaranteed. All warranty and liability claims are void if the maintenance work has not been carried out correctly or if unapproved spare parts have been used.

Measure	Maintenance interval	Remarks/notes
Check gear temperature	Every 3 months	Max. permissible temperature at housing: 110 °C In case of higher temperatures, refer to section 7.
Check running noise	Every 3 months	In case of changes, refer to section 7.
Check oil level	Every 3 months	Refer to sections 8.1.1 and 3.3.5
Check oil quality	Every 3 months	Refer to sections 8.1.1 and 3.3.5
Check gear unit for leak tightness	Every 3 months	
Visual inspection of painting	Every 3 months	Damage to the coating of the outer gear unit parts leads to failure of the corrosion protection and has to be touched up immediately.
Clean air vent	Every 3 months	Clean unscrewed air vent with petroleum ether or similar and dry or blow with compressed air. Ensure sufficient ventilation (explosion hazard)!
First oil change	After 2,000 operation hours	Refer to section 8.1.2
Further oil changes	After further 15,000 operating hours or 60 months	Refer to section 8.1.2
Clean gear unit	Every 12 months	Excessive water pressure and concentrated cleaning agents are not permitted for eliminating possible contamination.
Check fastening screws for tight fit	Every 12 months	Refer to section 5

Table 8: Corrective action and intervals

CAUTION!

Indications on oil change intervals only apply to polyglycoles according to section 3.3.5. Depending on the application and the deployment conditions, other lubricants might be required for which different maintenance intervals apply. Please refer to the contract documents (e.g. drawings) for further indications or contact AUMA Drives Service.

8.1. Description of maintenance work

8.1.1. Oil level and status monitoring



Oil and oil filling level may only be checked once gear unit has cooled down and is at standstill.

Checking the lubricant condition:

Open screw plug at oil drain (for position, refer to section 3.1) and drain a small quantity. Once the lubricant has been drained, seal oil drain according to specified tightening torque (table 8.1.1) (Caution: Fit sealing ring again!). Check the oil quality with regard to colour and for the quality of solid particles or contamination contained.



If required, request support with an external service provider or laboratory. Lubricant manufacturers also offer this type of testing. If required, change oil (refer to section 8.1.2).

Oil level monitoring:

Remove air vent with oil dipstick (refer to section 3.1), unscrew and wipe remaining oil off the oil dipstick. The oil level can only be read off again, once the air vent has been completely screwed in and removed again (refer to section 3.3.5). Check oil level in case of deviations.



Exclusively use lubricant of the same type (refer to name plate!) for refilling. Mixing oils of various types and manufacturers is not permissible (for selection, refer to table 3.3.5-1). In particular refrain from using mineral oils without the explicit prior consent of AUMA Drives.

Finally, the air vent valve has to be screwed in again, refer to tables 8.1.1 and 9.2 for the required tightening torque. Replace damaged sealing rings.

Size	Tightening torque of the air vent (oil infeed) [Nm]	Width hexagon socket of the screw plug at the oil drain [mm]	Tightening torque of screw plug at the oil drain [Nm]
S40.1-S80.1	10	5	10
S100.1-S125.1	20	6	20
S160.1	34	8	34
S200.1-S355.1	85	12	85
S200.1-S450.1	130	17	130

Table 8.1.1: Tightening torques of screw plugs and air vent valve

8.1.2. Oil change

Oil change has to be performed shortly after shut-down while still **at service temperature** (housing surface is hand warm). Otherwise complete draining cannot be ensured due to lack of viscosity.



Heat resistant gloves must imperatively be worn to avoid burns due to hot draining oil!

1. Place collecting basin underneath the oil draining screw plug.
2. Unscrew oil draining screw plug and air vent.

- The oil drain plug of sizes S200.-S450.1 are equipped with a magnet that collects ferromagnetic abrasion due to wear. The collected particles must be removed before reassembly.

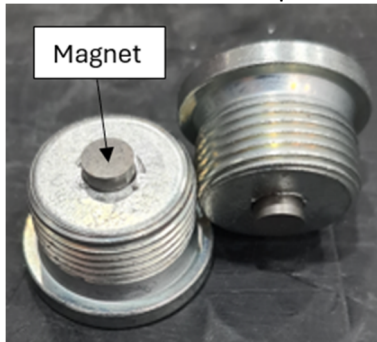

- Drain oil completely. If required, rinse gear unit with low-viscosity (and compatible) oil. Possible bronze flakes are uncritical.
- Seal oil drain: Tighten oil draining screw plug and sealing ring with tightening torque according to tables 8.1.1 and 9.2.
- Refill new oil (refer to section 3.3.5) via threaded hole of air vent up to required filling level (refer to section 8.1.1 "Oil level monitoring").
- Screw in air vent (for tightening torque, refer to tables 8.1.1 and 9.2)
- Contain spilled oil using a suitable agent and dispose of used oil according to national regulations.

8.1.3. Cleaning the air vent

Air vents designed as filters (type sizes S200.1-S450.1) can be dismantled for cleaning purposes. The filter insert can be removed after opening the cap. Cleaning can be carried out using compressed air.



Abbildung 8.1.3: Dismantling the vent filter

9. Screw tightening torques

9.1. Coarse pitch thread screws

Fastening screw	Tightening torque [Nm]		
	8.8	10.9	12.9
M4	3.1	4.5	5.25
M5	6.1	9	10.4
M6	11	15	18
M8	25	37	43
M10	51	75	87
M12	87	128	150
M16	214	314	365
M20	431	615	710
M24	742	1057	1220
M30	1489	2121	2450
M36	2594	3695	4280

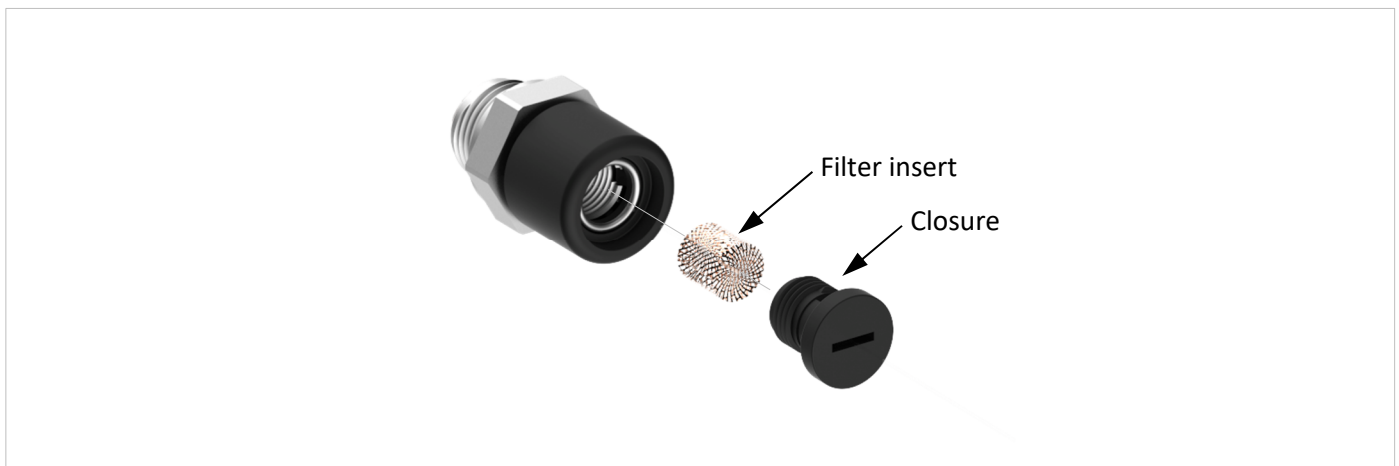
Table 9.1: Tightening torques for standard thread screws

9.2. Screw plugs

Screw plug St		Tightening torque [Nm]	Screw plug St		Tightening torque [Nm]
Metric fine thread in accordance with DIN 13	Pipe threads in accordance with EN ISO 228		Metric fine thread in accordance with DIN 13	Pipe threads in accordance with EN ISO 228	
M10 x 1.0	-	10	-	G 1/2	60
-	G 1/8 A	10	M22 x 1.5	-	60
M12 x 1.5	-	20	M26 x 1.5	-	70
-	G 1/4 A	26	M27 x 2.0	-	85
M14 x 1.5	-	30	-	G 3/4 A	85
M16 x 1.5	-	34	M33 x 2.0	-	130
-	G 3/8 A	34	-	G 1 A	130
M38 x 1.5	-	42	M48 x 1.5	G 1 1/2 A	150
M20 x 1.5	-	50	M60 x 2.0	G 2 A	170

Table 9.2: Tightening torques for screw plugs

Operation instructions

Worm gear unit
S40.1 – S450.1

10. Spare parts

CAUTION!

Only use original spare parts by AUMA Drives for maintenance work! We will not assume any liability or warranty for damage incurred when using other spare parts than provided by AUMA Drives. Furthermore, use of such products might impair both characteristics and operational reliability as well as safety of the gear unit.

10.1. Spare parts for sizes S40.1 – S80.1

The following spare parts only apply to basic version with drive shaft at input drive, hollow shaft at output drive, passive vent and service position B3. Deviating versions, service positions and gear units for special application and environmental conditions include other components. Please indicate the order number or serial number of the gear unit (refer to name plate) when ordering spare parts.

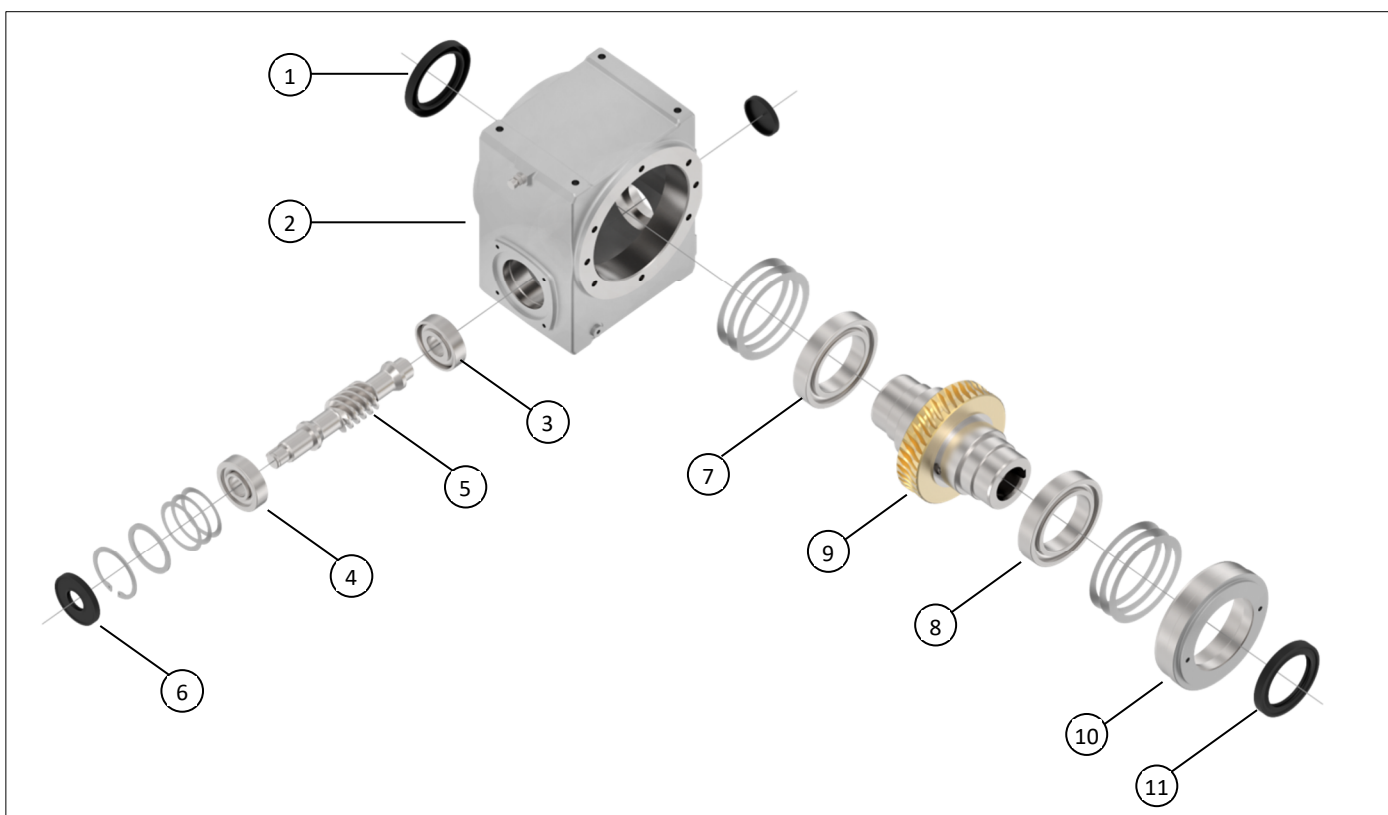

Figure 10.1: Exploded view for sizes S63.1 and S80.1 (deviating structure without SR bearing cover for sizes S40.1 and S50.1!)

No.	Spare part designation	S40.1	S50.1	S63.1	S80.1
1	Radial seal DIN3760-	AS35x52x7-FKM-G	AS50x72x8-FPG	AS50x72x8-FPG	AS65x90x10-FPG
2	Housing				
3	Ball bearing	DIN720-32004X-J	DIN720-32005X-J ⁽¹⁾ DIN628-7204-B-TN ⁽²⁾	DIN720-30205X-J ⁽¹⁾ DIN628-7304-B-TN ⁽²⁾	DIN720-31305X-J ⁽¹⁾ DIN628-7305-B-TN ⁽²⁾
4	Ball bearing	DIN720-30203-J	DIN720-32005X-J DIN628-7204-B-TN	DIN720-30205X-J DIN628-7304-B-TN	DIN720-31305X-J DIN628-7305-B-TN
5	Worm shaft				
6	Radial seal DIN3760-	AS20x42x7-FKM	AS20x47x7-FPG	AS20x52x8-FPG	AS25x62x7-FPG
7	Deep groove ball bearing DIN625-	16007-J	6010-J	6011-J	6014-J
8	Deep groove ball bearing DIN625-	16008-J	6011-J	6011-J	6014-J
9	Worm wheel				
10	SR bearing cover	<i>n/a</i>	<i>n/a</i>		
11	Radial seal DIN3760-	AS40x68x8-FKM-G	AS50x90x10-FPG	AS50x72x8-FPG	AS65x90x10-FPG

Table 10.1: Wear parts S40.1 – S80.1

⁽¹⁾ for i=12.75 (13); 25 (25.5); 51 (53); 61 (62); 82 (83)

⁽²⁾ for i=5 (4.83); 7.5 (7.25); 10 (9.5 & 9.75); 15 (14.5); 20 (19 & 19.5), 30 (29); 40 (38 & 39)

Operation instructions

Worm gear unit
S40.1 – S450.1

10.2. Spare parts for sizes S100.1 – S160.1

The following spare parts only apply to basic version with drive shaft at input drive, hollow shaft at output drive, passive vent and service position B3. Deviating versions, service positions and gear units for special application and environmental conditions include other components. Please indicate the order number or serial number of the gear unit (refer to name plate) when ordering spare parts.

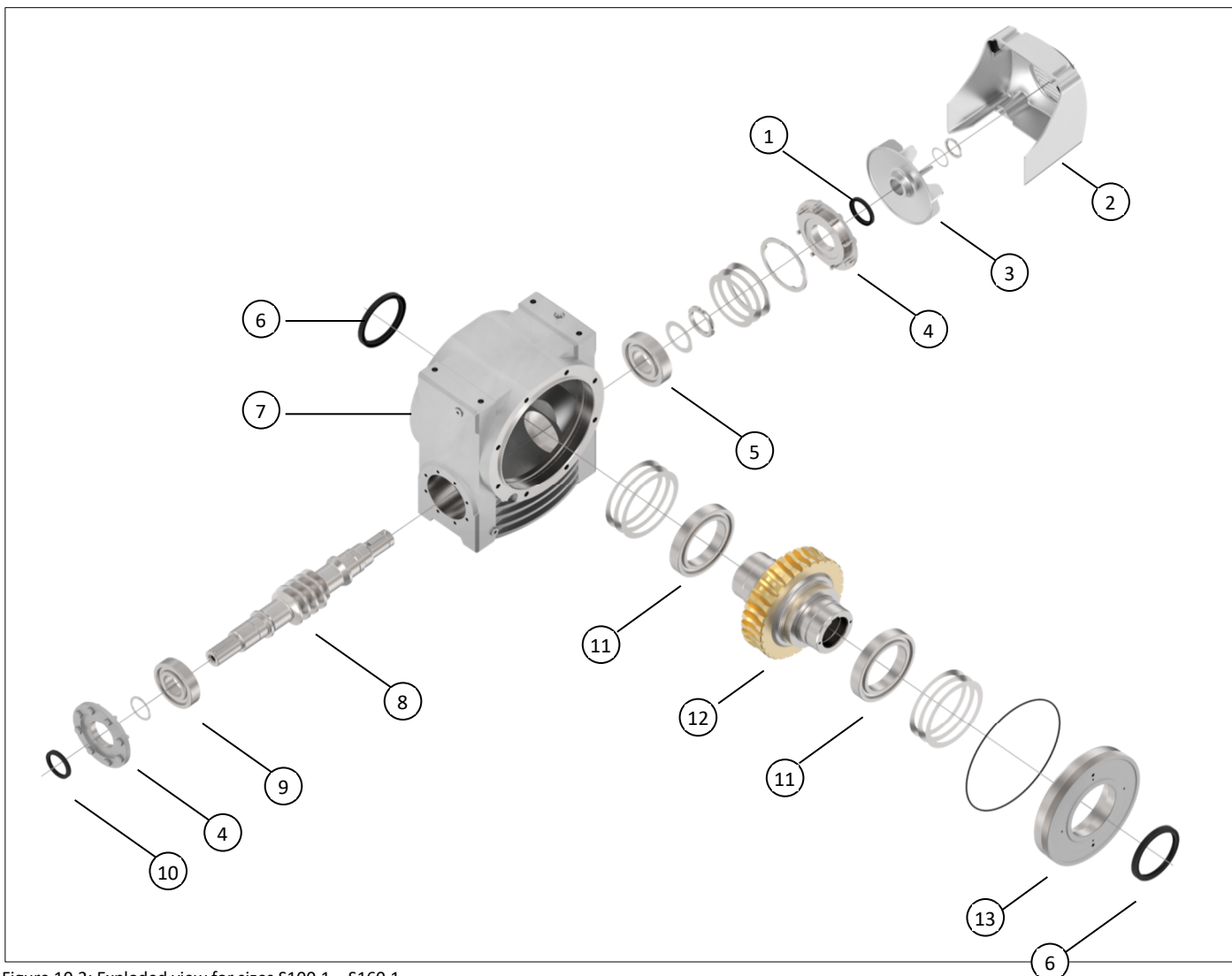

Figure 10.2: Exploded view for sizes S100.1 – S160.1

No.	Spare part designation	S100.1	S125.1	S160.1
1	Radial seal DIN3760-	AS35x62x12-70...80FPM	AS42x72x8-FKM-G	AS55x72x8-FP-G
2	Fan hood			
3	Fan wheel			
4	SW bearing cover			
5	Angular ball bearing DIN628-	QJ 308-TN	QJ 309-TN	QJ 312-PHAS
6	Radial seal DIN3760-	AS85x110x12—FP-G	AS95x120x10-FPM-G	AS115x140x12-FP-G
7	Housing			
8	Worm shaft			
9	Deep groove ball bearing DIN625-	6308-J	6309-J	6311-J
10	Radial seal DIN3760-	AS35x62x12-70...80FPM	AS45x72x8-FKM-G	AS55x72x8-FP-G
11	Deep groove ball bearing DIN625-	6017-J	6020-J	6024-J
12	Worm wheel			
13	SR bearing cover			

Table 10.2: Wear parts S100.1 – S160.1

Operation instructions

Worm gear unit
S40.1 – S450.1

10.3. Spare parts for sizes S200.1 – S450.1

The following spare parts only apply to basic version with drive shaft at input drive, hollow shaft at output drive, passive vent and service position B3. Deviating versions, service positions and gear units for special application and environmental conditions include other components. Please indicate the order number or serial number of the gear unit (refer to name plate) when ordering spare parts.

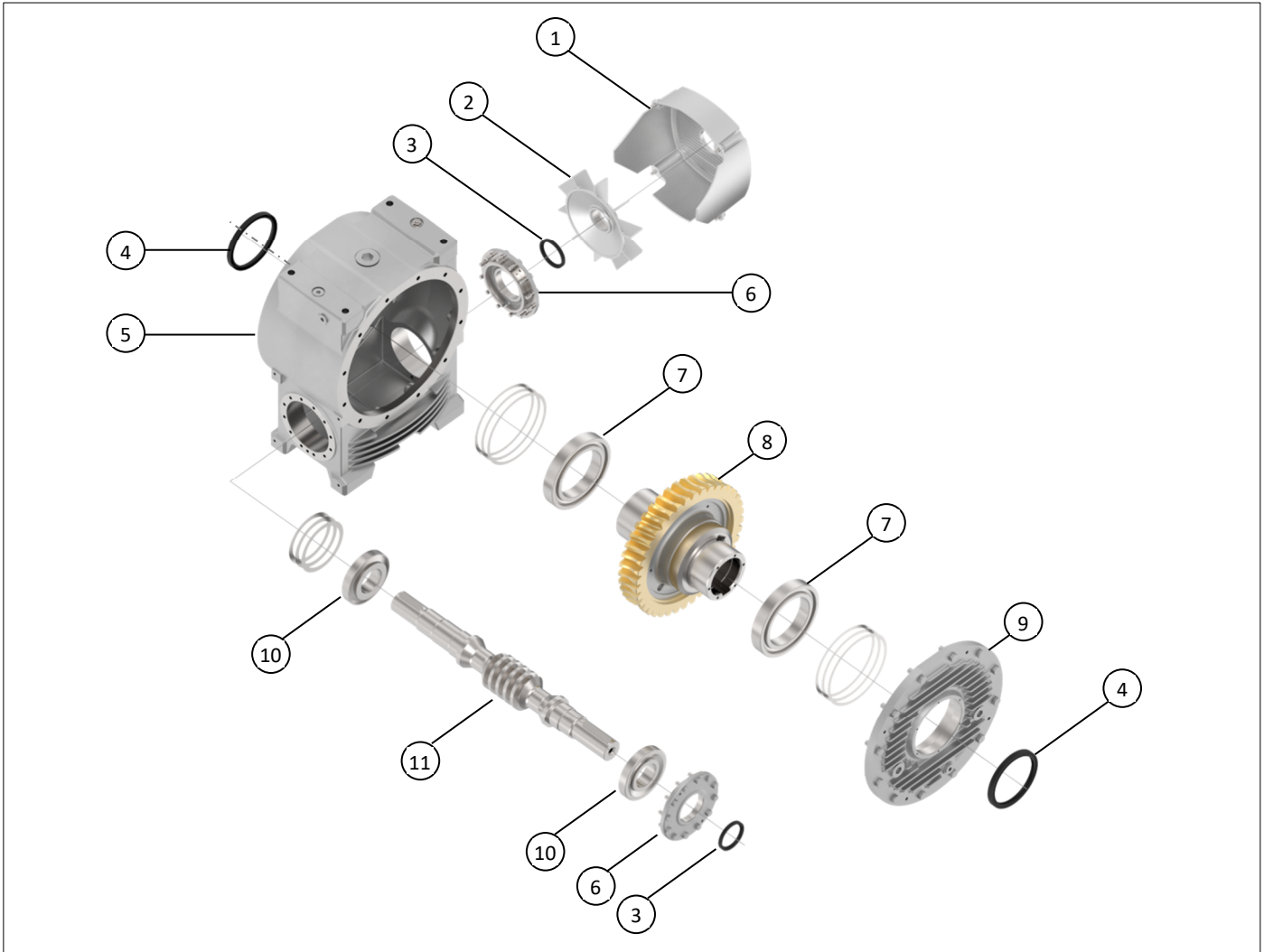

Figure 10.3: Exploded view for sizes S200.1 – S450.1

No.	Spare part designation	S200.1	S225.1	S250.1	S280.1	S315.1	S355.1	S400.1	S450.1
1	Fan hood								
2	Fan wheel								
3	Radial seal DIN3760-	AS60x85x8-FKM-G	AS75x95x10-FKM-G	AS75x95x10-FKM-G	AS85x120x12-FKM-G	AS95x120x12-FKM-G	AS95x120x12-FKM-G	AS105x140x12-FKM-G	AS115x140x12-FKM-G
4	Radial seal DIN3760-	AS130x160x12-FKM-G	AS160x190x15-FKM-G	AS160x190x15-FKM-G	AS180x210x15-FKM-G	AS200x230x15-FKM-G	AS220x250x15-FKM-G	AS260x300x20-FKM-G	AS280x320x20-FKM-G
5	Housing								
6	SW bearing cover								
7	Deep groove ball bearing DIN625-	6026-J	6032-J	6032-J	6036	6040-J	6044-M	6052-M	6056-M
8	Worm wheel								
9	SR bearing cover								
10	Tapered roller bearing DIN720-	31313-J	31316-J	31316-J	31320X-J	31320X-J	31320X-J	31322X-J	31324X-J
11	Worm shaft								

Table 10.3: Wear parts S200.1 – S450.1

11. Disposal

Our gear units have a long service life. However, they have to be replaced at one point in time. Individual components have to be disposed of as follows:



- Housing parts, worm shaft, shafts and roller bearings are to be disposed of as scrap steel.
- Parts made of cast iron are also to be handled as scrap steel, in case there is no separate collection.
- Worm wheels made of bronze have to be disposed of separately.
- Greases and oils are hazardous to water and must not be released into the environment. They have to be collected and disposed of according to the relevant environmental provisions (national regulations and directives for waste disposal, e.g. ISO 140001).

12. Appendix I: Declaration of Incorporation

 Solutions for a world in motion	AUMA Drives GmbH Grenzstraße 5 D-01640 Coswig www.auma-drives.com	Tel. +49 3523 94 60 Fax +49 3523 74 675 info@auma-drives.com
Drives		
EC Declaration of Incorporation		
according to EC machinery directive 2006/42/EC dated 17 May 2006, appendix II B		
The manufacturer		
AUMA Drives GmbH Grenzstraße 5 D-01640 Coswig/ Germany		
declare herewith that the above mentioned gear units comply in their conception and design as well as in the versions distributed with the basic requirements for safety and health of the EC Directive 2006/42/EC, considering particularly appendix 1, paragraphs 1.1.2, 1.1.3, 1.1.5, 1.3.1, 1.3.7, 1.7.1., 1.7.3, 1.7.4.		
With regard to the partly finished machine, the manufacturer commits to submitting the documents to the competent national authority via electronic transmission upon reasonable request. The relevant technical documentation pertaining to the partly completed machinery described in Annex VII, part B has been prepared.		
The partly finished machine must not be put into service until the machinery into which the AUMA Drives unit is to be incorporated has been declared in conformity with the provisions of the EC Directive (2006/42/EC).		
Description of the partly finished machinery:		
	Worm gear units	
	Spur gear units	
	Worm-spur gear units	
	Spur-worm gear units	
	Double worm gear units	
	Slewing gear units	
	Screw jacks	
	Cross-helical gears	
	Bevel gearboxes	
	Planetary gears	
	Hypoid gear units	
	Hypoid- helical gear units	
Applied harmonised standards:		
	DIN EN ISO 12100:2011 Safety of machinery	
	General principles for design - Risk assessment and risk reduction	
Authorised person for technical documentation:		
	Michael Eleser, Grenzstraße 5, D-01640 Coswig	
		
Coswig	2022-02-07	
Ort	Date	Markus Weber, Managing Director
Y050.082/EN		
This declaration does not contain any guarantees. The safety instructions in product documentation supplied with the devices must be observed. Non-concerted modification of the device components voids this declaration.		

AUMA Drives GmbH
Grenzstr. 5
01640 Coswig/Germany
Phone: +49 (0) 3523 94 60
www.auma-drives.com

AUMA Drives Service
Phone: +49 (0) 3523 94 60
service.driv@auma.com



PM-MS
Y050.087
BA_S40.1_S450.1_EN_12.2024